

Business Informatics 2 (PWIN)
SS 2021

Communication Systems I
Layer-based Communication

Prof. Dr. Kai Rannenber

Chair of Mobile Business & Multilateral Security
Johann Wolfgang Goethe University Frankfurt a. M.

- Introduction: Information & Communication
- OSI Model
 - OSI Model Overview
 - Layer 2: Data Link Layer
 - Layer 3: Network Layer
 - Layer 4: Transport Layer
 - Layer 7: Application Layer

- **Data:** Characters (symbols), which are based on mutual agreements, represent information in an electronically processable manner.
- **Knowledge:** Contents containing the beliefs about the truth of statements. (Wittmann, 1959)
- **Information:** Explicit (in the form of language expressed) knowledge, which is used by humans in order to accomplish business objectives. → purposeful knowledge (Wittmann, 1959)
- **Communication:** Exchange of information between humans as well as exchange of data between machines.

- A communication system is a collection of
 - Hardware (terminals, physical network components),
 - Software (operation systems, network protocols, application systems) and
 - Transmission protocols,

which are compatible with each other and allow an exchange of information - for example between enterprise sites.



Information



The screenshot shows the website for the mobile business chair at Goethe University. The main content area displays details for a lecture in SS 10 titled 'Wirtschaftsinformatik 2 (PWIN)'. The page includes a search bar, navigation menu, and social media links.

Allgemeine Informationen ausblenden	
Zielgruppe:	<ul style="list-style-type: none"> Zielgruppe ausblenden Vorlesung + Übung: Bachelorstudium Vertiefungsstudium BA VertSt: V + U
Kursbezeichnung/ Kürzel:	PWIN (Bachelor)
Semester:	SS 10
Dozenten/-innen:	<ul style="list-style-type: none"> Prof. Dr. Kai Rannenberg Dipl.-Wirt.-Inf. Stephan Heim Dipl.-Ing. (FH), MBA Christian Weber
Zeit und Ort:	Zeit und Ort werden noch bekannt gegeben.
Erweiterte Informationen ausblenden	
Erste Veranstaltung:	13.04.2010

- Introduction: Information & Communication
- OSI Model
 - OSI Model Overview
 - Layer 2: Data Link Layer
 - Layer 3: Network Layer
 - Layer 4: Transport Layer
 - Layer 7: Application Layer

- In order to **reduce complexity** of communication systems, most networks are built using **multiple layers**, one upon the other.
- In all networks, layers provide specific **services** to the layer above while, in particular, shielding it from details such as **how** these services are provided or implemented.
- In informatics, this concept is known from the areas of **abstract data types, data encapsulation and object-oriented programming**.

5-layer Model

- The figure shows 5 layers.
- Communication inside one layer uses the respective **protocol**.
 - In telecommunication, a communication **protocol** is a system of rules that allow two or more entities of a communications system to transmit information via any kind of variation of a physical quantity. The protocol defines the rules syntax, semantics and synchronization of communication and possible error recovery methods (Wikipedia).
- **No direct data communication** from layer n of one host to the same layer n of another host.
- Each layer sends data and control messages to the layer below until the lowermost layer was reached.
- Located below layer 1 is the physical transmission medium which is used for the communication.

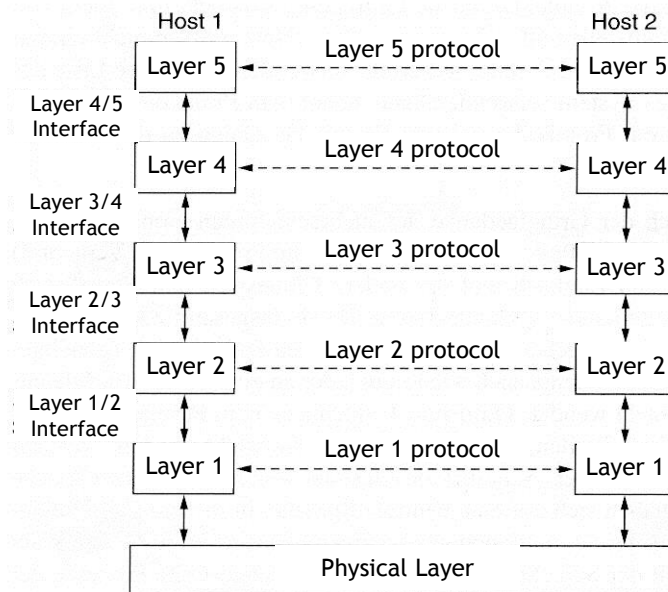

- Development of the OSI model
 - The **OSI Model** is based on a proposal of the International Standards Organization (ISO) (1983).
 - In 1995, it was revised (Day und Zimmermann) and is since then named **OSI Reference Model**.
 - OSI means für **Open System Interconnection**. Open Systems are open for communication with other systems.

OSI Reference Model

- The OSI reference model consists of **seven** layers:
 - **Layers 1-4** are **transport-oriented** layers as they focus on the transportation of bits.
 - **Layers 5-7** are **application-oriented** layers as they support the use of data transport applications.
 - The following basic ideas have lead to the 7 layers:
 - Whenever a new **level of abstraction** is necessary, a new layer has to be introduced
 - Each layer should deal with one well-defined task or function.

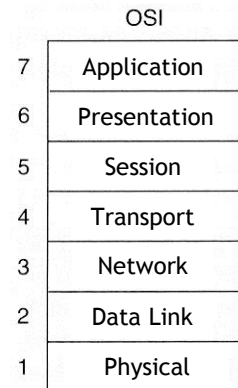

OSI Reference Model

- When choosing the relevant functions, protocols should be respected which were previously standardised on an international level.
- Boundaries between layers should be chosen in a way that information flow through interfaces is minimised.
- The number of layers should be sufficiently big to not have different functions grouped inside one layer, but also small enough to not be left with an unmanageable model or architecture.

Layer 1: Physical Layer

- The **physical layer** is the lowermost layer of the OSI model. It defines **mechanical, electrical and time-related** specifications for interfaces to the network. It deals with the **transmission of bits** over a communication channel.
- Typical transmission-related questions are:
 - How to represent bits?
 - Definition and assignment of connectors and pins.
 - How to achieve full-duplex transmission (both directions simultaneously)?
 - Connection set-up and termination
 - Which are the available transmission media?

Layer 2: Data Link Layer

- The **data link layer** contains **algorithms for efficient and reliable communication** between neighbouring communicating parties.
 - **Tasks are:**
 - Error control
 - Flow control
 - Error detection and correction
 - **This can be assured by:**
 - Segmentation; allocation of data to small packets to be passed on sequentially
 - Confirmation; every packet which was properly received is confirmed by the communicating party which receives it
 - ...

Layer 3: Network Layer

- The **network layer** takes care of the transmission of packets **from the source to the destination**. This may also include *passing through* network segments on the way between two routers.
 - The main task of this layer is **routing**.
 - Network Layer needs to know about the topology of the communication network in order to be able to choose an adequate path for each packet
 - A path must be chosen carefully in order to avoid capacity overload or congestion of (sub)networks.

Layer 4: Transport Layer

- The **transport layer** is the core of the protocol hierarchy. It ensures reliable and cost-effective transport of data from the source to the destination, independent from physical networks (**logical end-to-end connection**). Cost-effective often means the shortest path.
- Tasks include:
 - Logical set-up of end-to-end connections
 - Receiving data from the session layer (layer 5) and dividing it into smaller segments, handing these segments over to the network layer (layer 3), keeping track and ensuring that all of them are received by the receiving party.

- The **session layer** enables users to start sessions from different computers. Data exchange is structured.
- Tasks include:
 - Dialogue control; managing which user is allowed to transfer data at a particular time.
 - Token Management; preventing two users from performing a critical operation at the same time.
 - Synchronisation; for long sessions restoration points are created. These allow to resume the transmission after an interruption.

Layer 6: Presentation Layer

- Unlike the lower layers that deal with the transmission of bits, the tasks of the **presentation layer** is concerned with the syntax and semantics of information to be transmitted.
- In order to enable computers to communicate based on different representations of data, this data needs to be defined at least in an abstract way.
- The presentation layer maintains these abstract data types and enables their usage for data exchange on the application layer.
 - Tasks include:
 - Data representation conversions
 - Data compression
 - Data encryption

Layer 7: Application Layer

- The **application layer** contains a multitude of protocols often needed by users for their applications to work.
 - Examples:
 - DNS,
 - E-Mail,
 - HTTP,
 - FTP,
 - ...

- Introduction: Information & Communication
- OSI Model
 - OSI Model Overview
 - Layer 2: Data Link Layer
 - Layer 3: Network Layer
 - Layer 4: Transport Layer
 - Layer 7: Application Layer

Layer 2: Data Link Layer Definition

- The **data link layer** contains **algorithms for efficient and reliable communication** between neighbouring communicating parties.
- The primary objective of the data link layer is the **smooth transmission of bits** from the source to the target, i.e. to the counterpart which was initiated by the network layer (layer 3) above.
- The data link layer provides services for the network layer (layer 3) to allow for frictionless transmission.

Layer 2: Data Link Layer

MAC Address

Media Access Control address (MAC address)

- Globally **unique identifier** for a network interface (“hardware address”)
- Used on physical networks such as **ethernet**, **wireless LANs (Wi-Fi)**, **bluetooth** and fibre-based technologies
- Assigned by manufacturer of the interface
- Length of the identifier: **6 byte (48 bit)**
- Network devices (e.g. switches, network adapter) need MAC addresses in order to be explicitly addressed on layer 2 if required by a service on higher layers.
- MAC addresses of Wi-Fi network interfaces are some-times used to allow or restrict access to Wi-Fi networks.

Layer 2: Data Link Layer

MAC Address

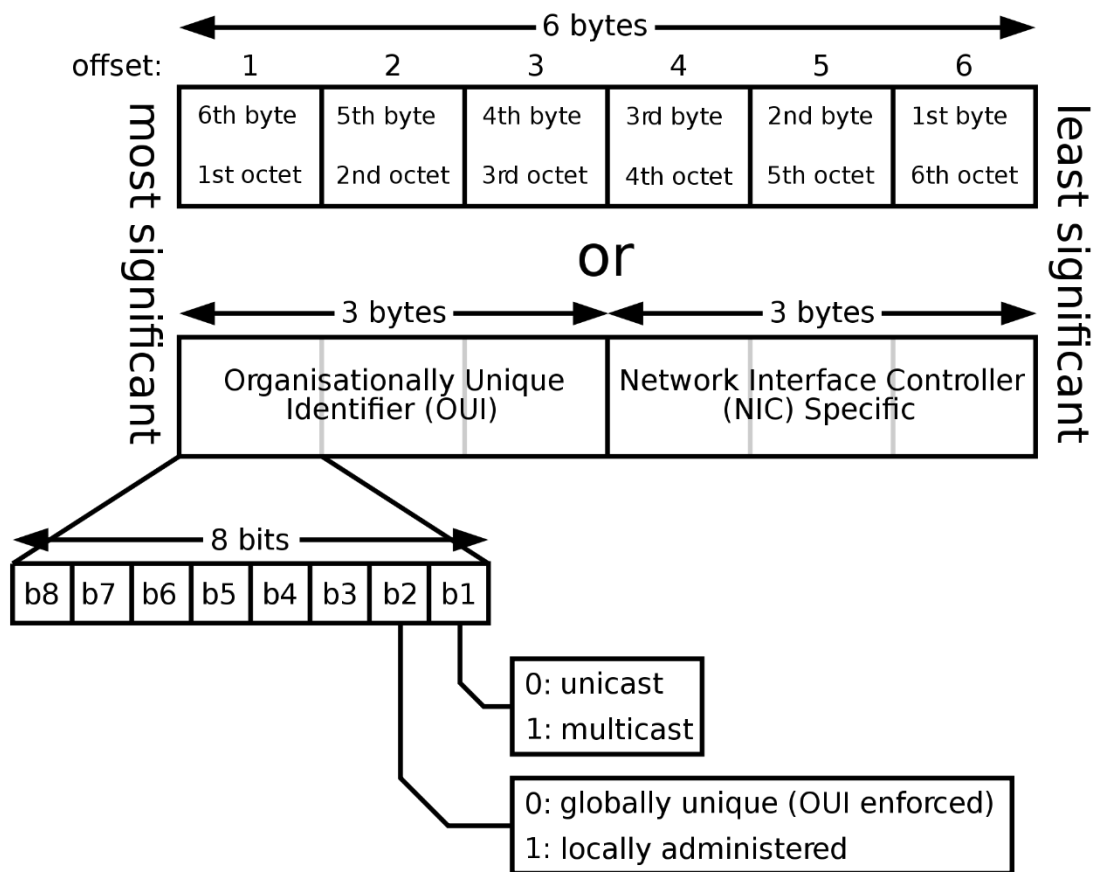

Layer 2: Data Link Layer Tasks

- Error handling
 - Send enough redundant data (i.e. error correction codes) in order to allow a recipient to “repair” incomplete or incorrect messages
 - Send enough redundant data (i.e. error detection codes) in order to allow a recipient to “detect” incomplete or incorrect messages
- Flow control
 - Ensures that a recipient receives only that amount of messages that it is actually able to process
- Management of concurrent access
 - Allows concurrent access to a network by managing/avoiding collisions of messages from multiple users

- Introduction: Information & Communication
- OSI Model
 - OSI Model Overview
 - Layer 2: Data Link Layer
 - Layer 3: Network Layer
 - Layer 4: Transport Layer
 - Layer 7: Application Layer

Layer 3: Network Layer Definition

- The network layer takes care of the transmission of packets **from the source to the destination**. This may also include *passing through* network segments on the way between two routers.
 - The main task of this layer is **routing**.
 - Internet Protocol (IP) is the protocol used in the network layer.

Layer 3: Network Layer Routing

- Routing is the process of selecting paths and forwarding packets while making sure the best possible path to the destination network is used.
- Best possible means:
 - Low transport costs
 - Fastest possible transport
 - Bug-proof transmission
 - Tamper-resistant transmission
 - Optimised network load
 - Weighted according to a combination of the criteria above
 - etc.

- Various routing algorithms exist:
 - Bellman equation (“Principle of Optimality”)
 - **Dijkstra Algorithm**
 - Ford Algorithm
 - Distance Vector Routing
 - Link State Routing
 - Hierarchical Routing
 - Broadcast Routing
 - Multicast Routing
 - ...

Layer 3: Network Layer Routing - Dijkstra Algorithm

- The algorithm was developed 1959 by Edsger Wybe Dijkstra.
- It solves the problem of finding the shortest path between two vertices (*singular: vertex*) in a graph.
- For this concept, a graph is created in which every router is represented by a **vertex** and every transmission line by an **edge**.
- The algorithm computes the shortest path between a selected pair of (two) routers with the help of this graph.
- The labels of the **edges** can e.g. be distance, bandwidth, average traffic, transmission costs, average queue length, average transmission time measured or other factors.
- Every **weighted edge** has an impact on the shortest path.

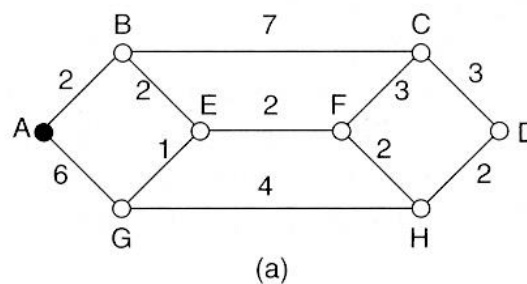

Source: Tanenbaum (2006), p. 391-393

Layer 3: Network Layer Using Dijkstra Algorithm

- Shortest path from A to H?
- Initial state of graph

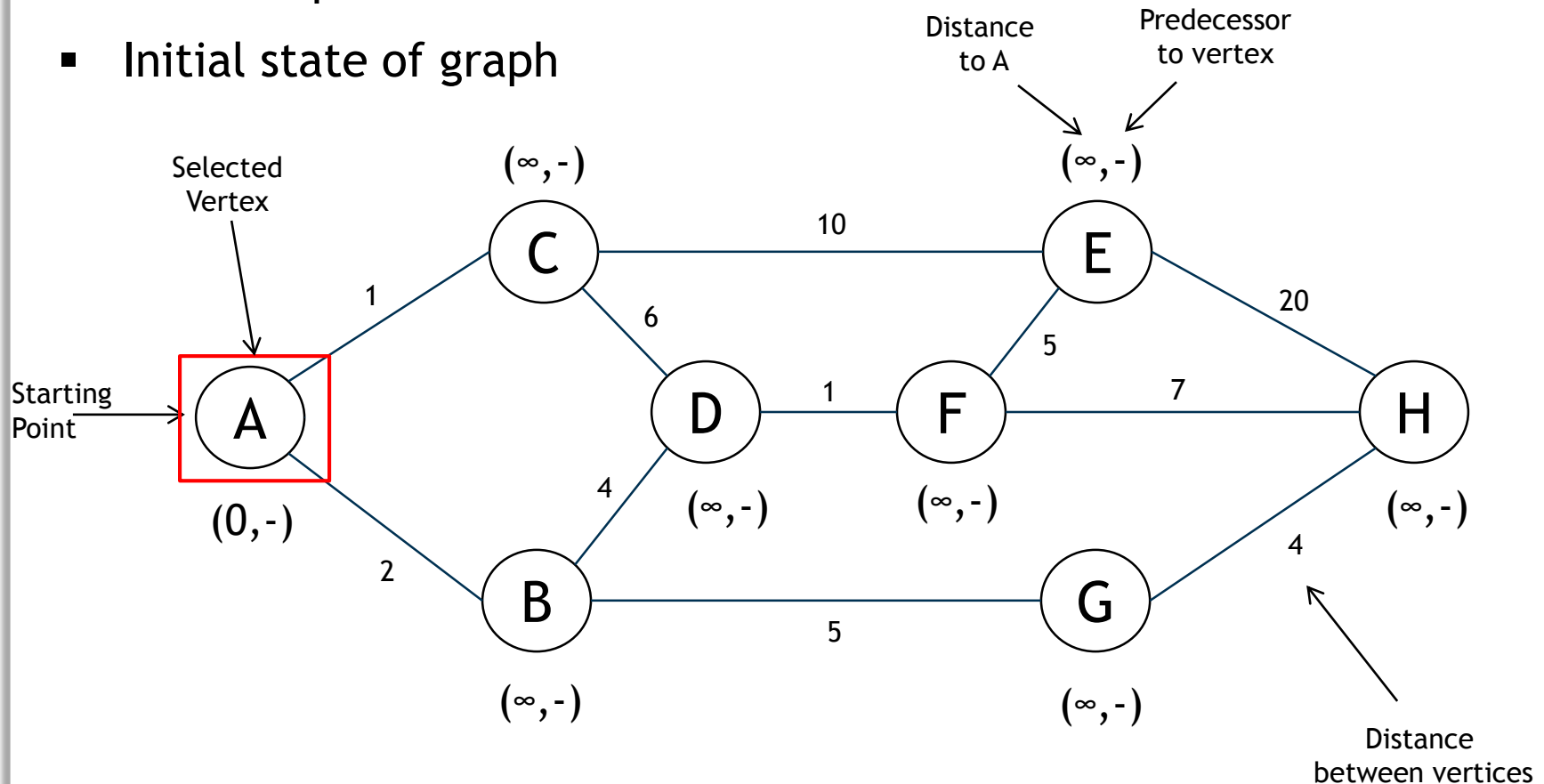

Layer 3: Network Layer Using Dijkstra Algorithm (2)

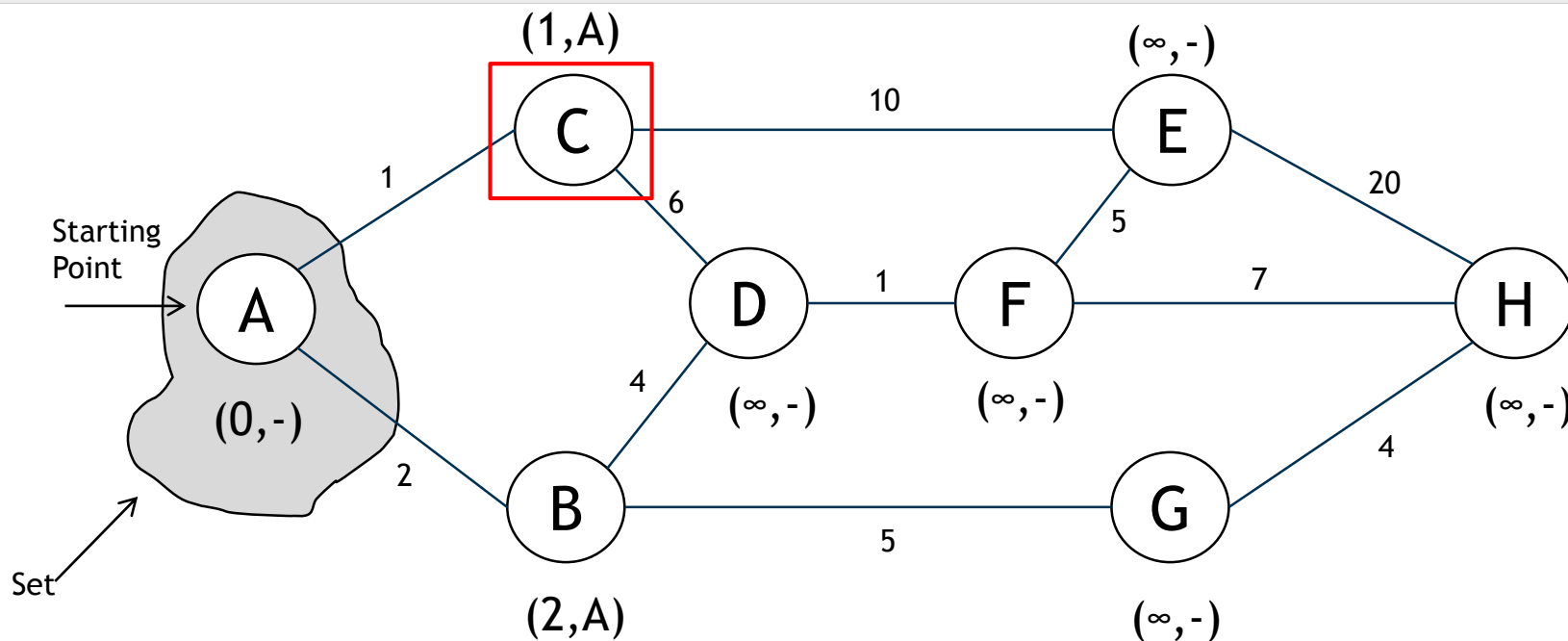

- Add last selected vertex to the set: A
- If shorter, update distance and predecessor values of the neighbours of the last selected vertex: B and C
- Select the vertex, which is not in the set and has the minimum value: C

Layer 3: Network Layer Using Dijkstra Algorithm (3)

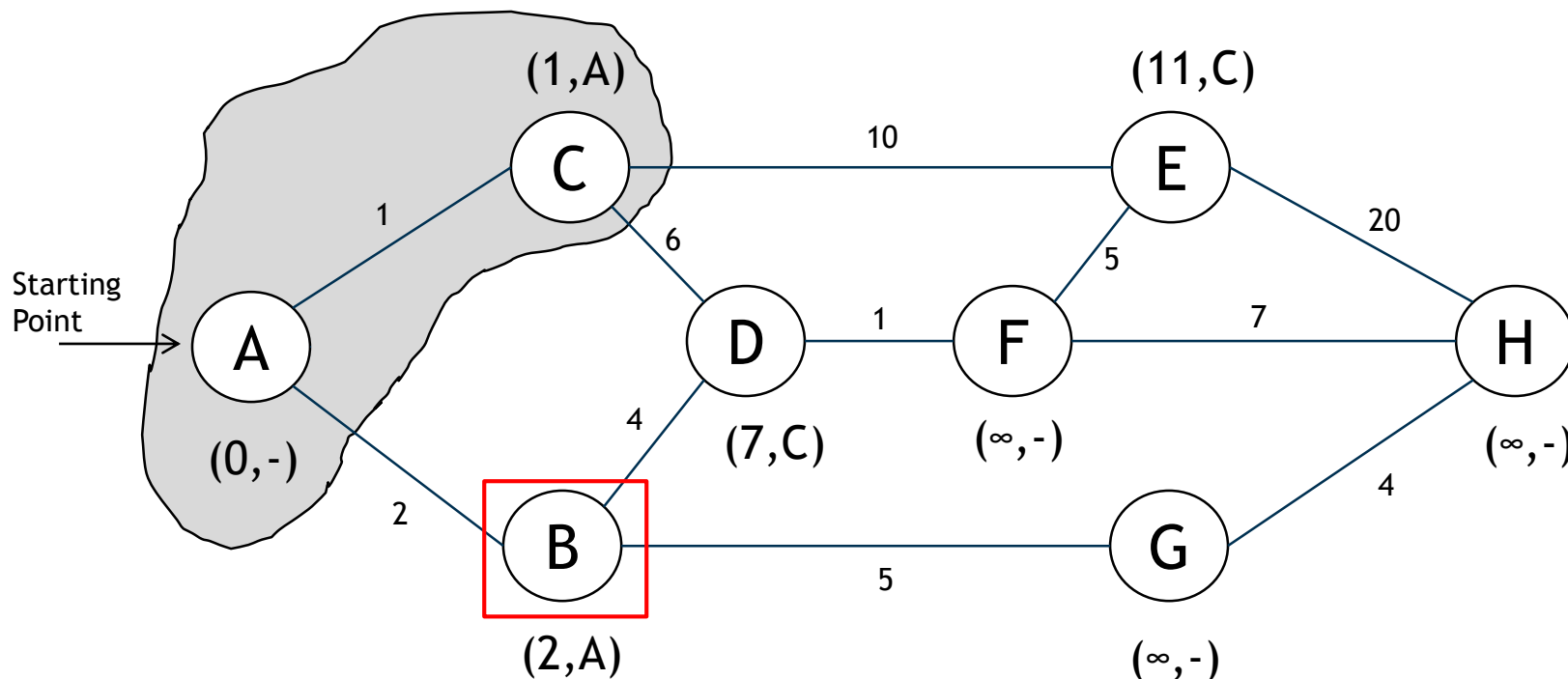

- Add last selected vertex to the set: C
- If shorter, update distance and predecessor values of the neighbours of the last selected vertex: D and E
- Select the vertex, which is not in the set and has the minimum value: B

Layer 3: Network Layer Using Dijkstra Algorithm (4)

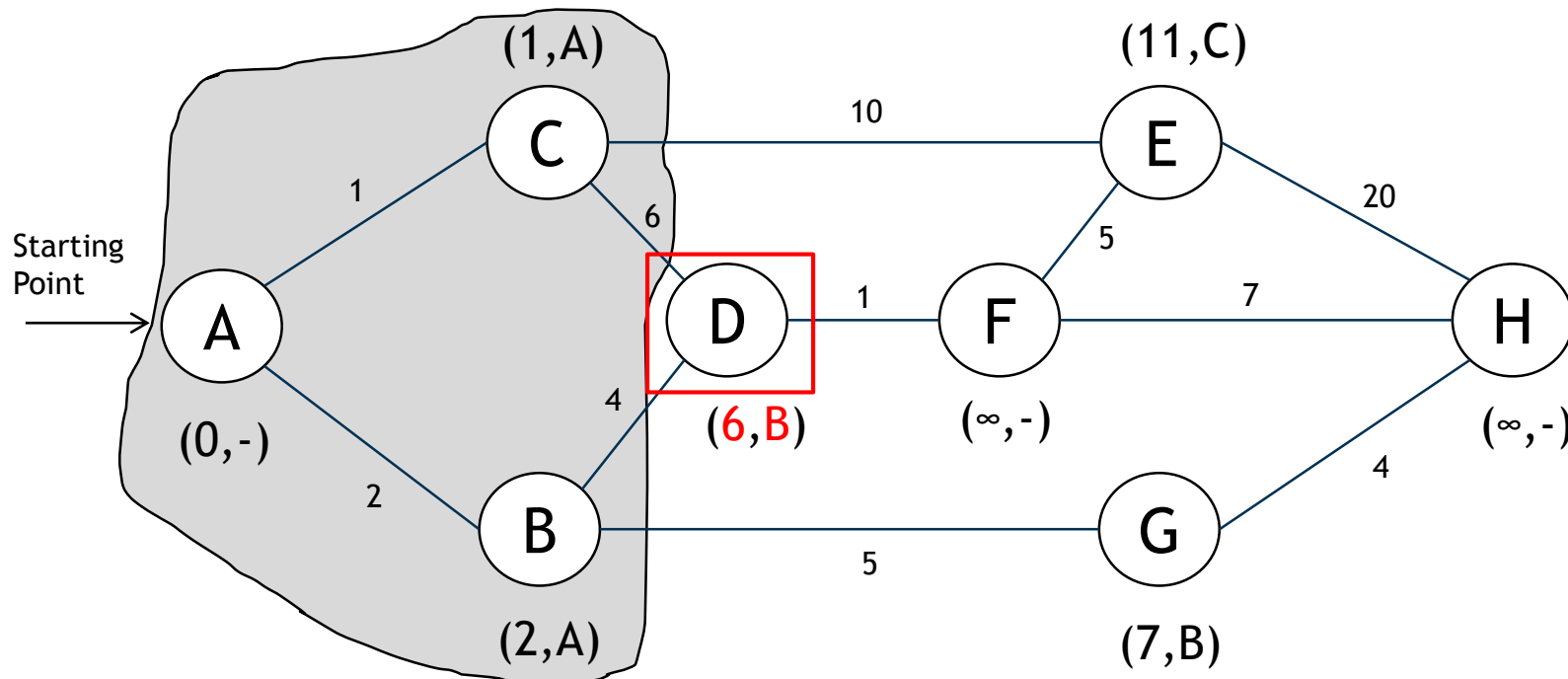

- Add last selected vertex to the set: B
- If shorter, update distance and predecessor values of the neighbours of the last selected vertex: D and G
- Select the vertex, which is not in the set and has the minimum value: D

Layer 3: Network Layer Using Dijkstra Algorithm (5)

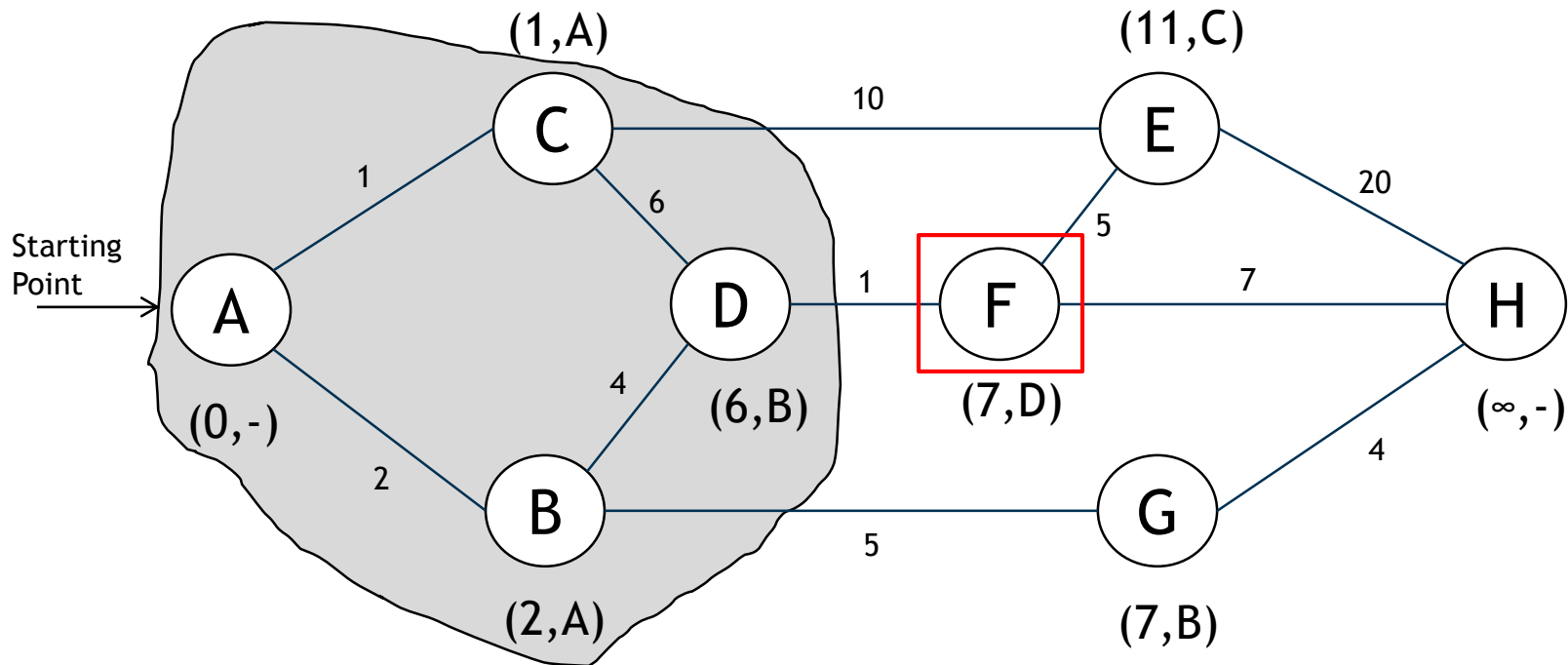

- Add last selected vertex to the set: D
- If shorter, update distance and predecessor values of the neighbours of the last selected vertex: F
- Select the vertex, which is not in the set and has the minimum value: F (if two minimum values exist, pick one randomly)

Layer 3: Network Layer Using Dijkstra Algorithm (6)

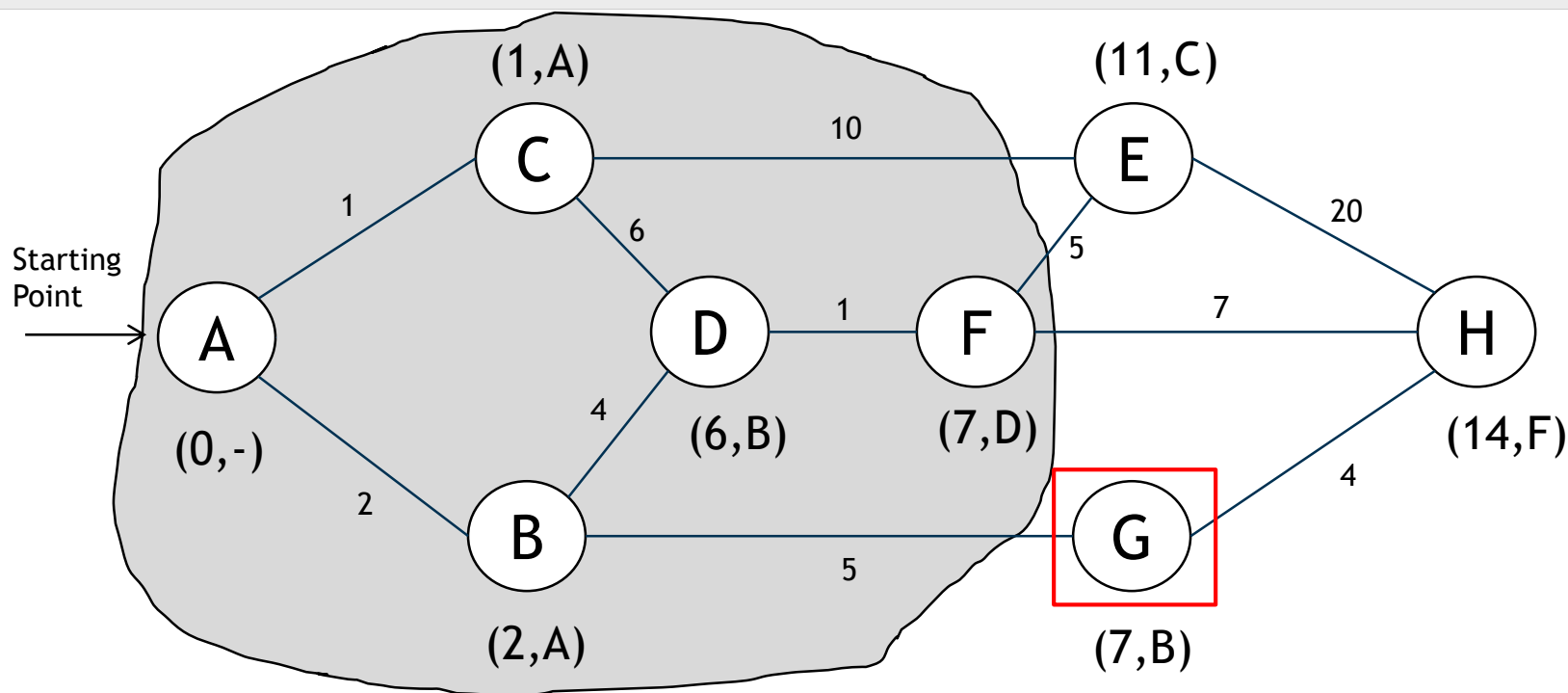

- Add last selected vertex to the set: F
- If shorter, update distance and predecessor values of the neighbours of the last selected vertex: E and H
- Select the vertex, which is not in the set and has the minimum value: G

Layer 3: Network Layer Using Dijkstra Algorithm (7)

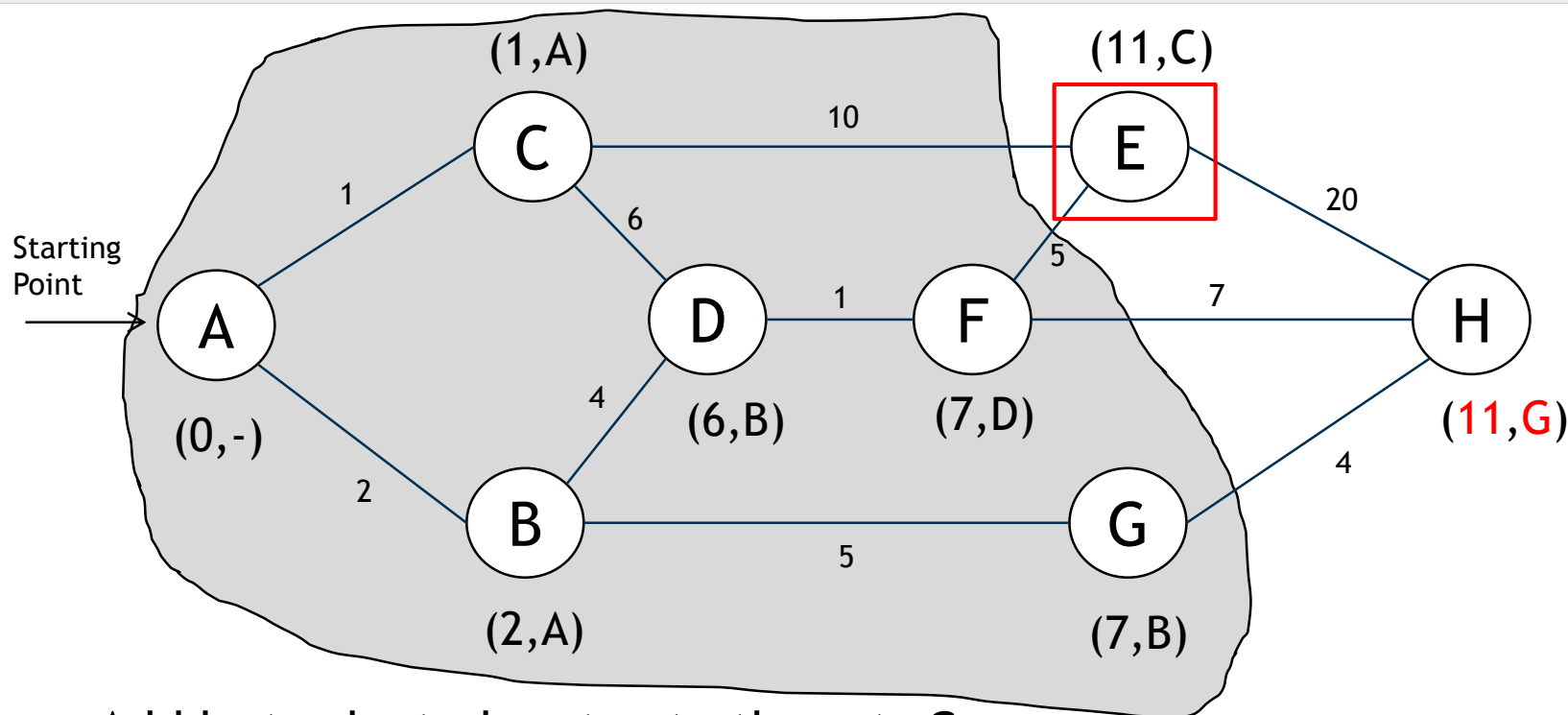

- Add last selected vertex to the set: G
- If shorter, update distance and predecessor values of the neighbours of the last selected vertex: H
- Select the vertex, which is not in the set and has the minimum value: E (if two minimum values exist, pick one randomly)

Layer 3: Network Layer Using Dijkstra Algorithm (8)

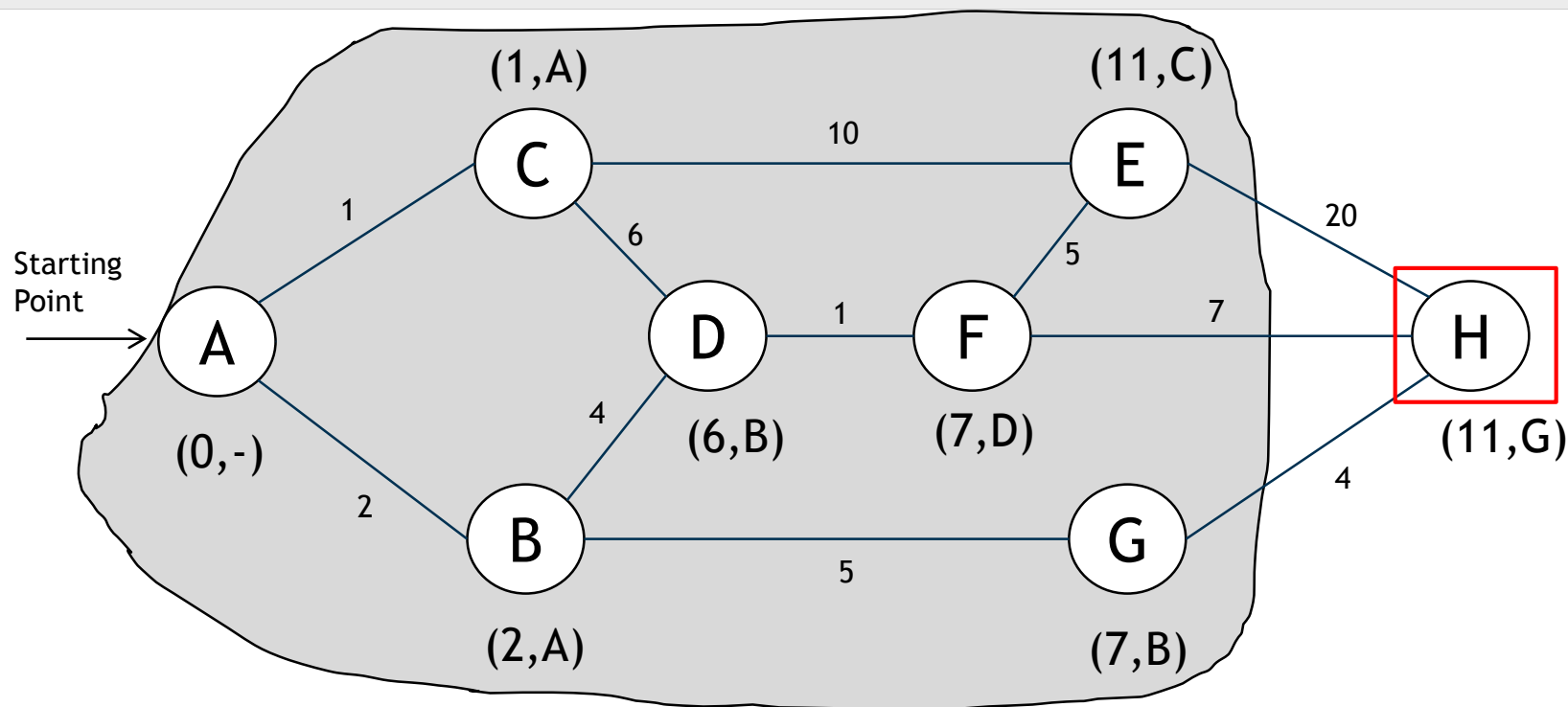

- Add last selected vertex to the set: E
- If shorter, update distance and predecessor values of the neighbours of the last selected vertex: H
- Select the vertex, which is not in the set and has the minimum value: H

Layer 3: Network Layer Using Dijkstra Algorithm (9)

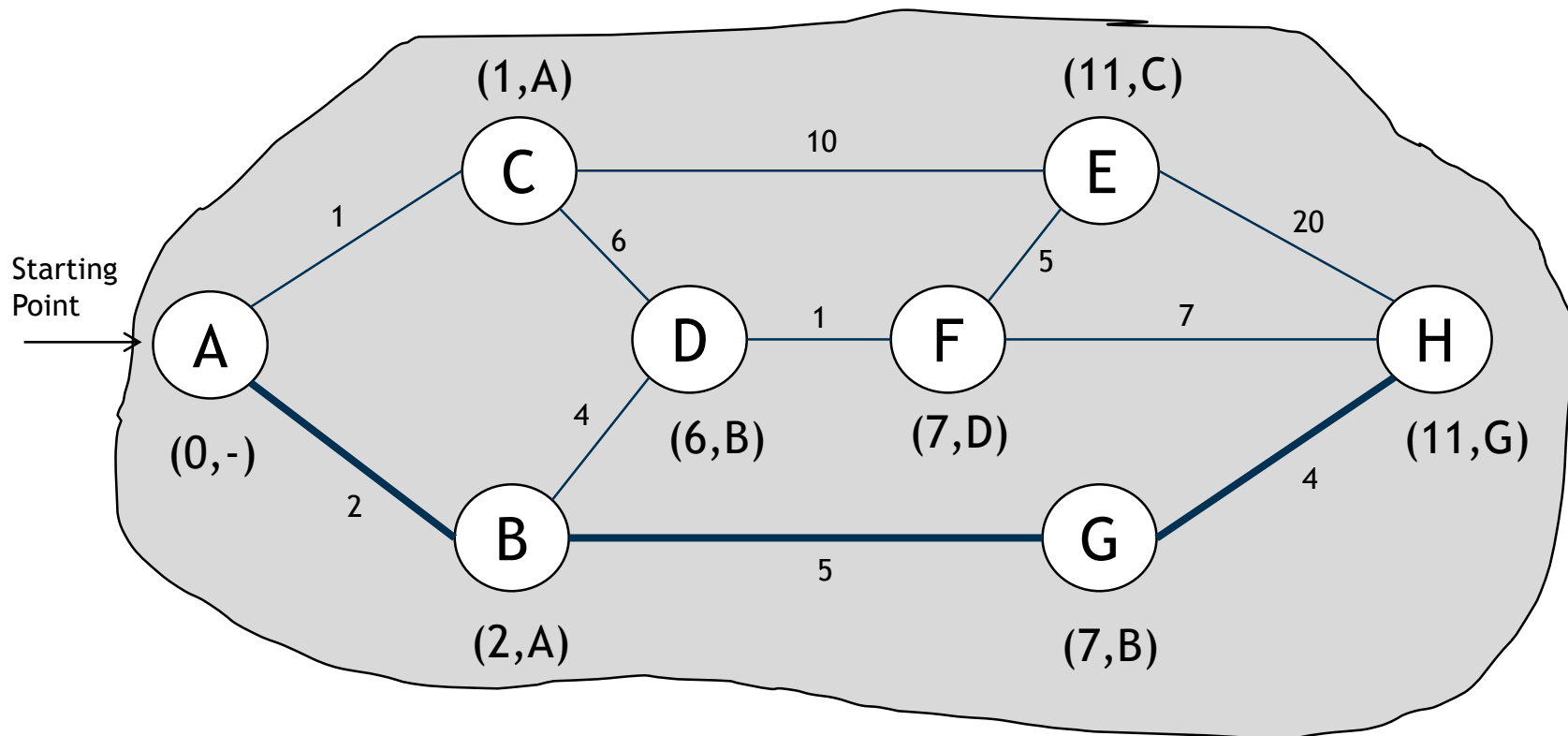

- Add last selected vertex to the set: H
- Predecessor labels allow to find the shortest path (A,B,G,H) → 11

Layer 3: Network Layer Internet Protocol (IP)

- The task of the Internet Protocol (IP) is (cross-network) transportation of data packets from one sender to one receiver. Multiple networks are typically used here.
- Transmission is
 - packet-oriented,
 - connectionless and
 - not guaranteed.
- In September 1981, the Internet Protocol was specified in RFC 791.

Layer 3: Network Layer

Internet Protocol (IP)

- Terms:
 - **Packet:** A packet is a data block (a given amount of bits) along with the necessary information to serve it to the addressee (like a parcel).
 - **Datagram:** A datagram is the packet format which is defined by the IP. It determines how the bits have to be arranged in order for the packet to be recognised as a well-formed IP-packet.
- Subtasks of the IP:
 - Forwarding of data from transport layer (layer 4) to network layer (layer 3)
 - Routing of datagrams through the network
 - Fragmentation and reassembling of datagrams
 - Definition how hosts have to be addressed.

Layer 3: Network Layer Internet Protocol (IP v4)

IPv4 Packet format

- The IP header consists of the following parts:

- Version
- IHL (header length)
- Type of service
- Total length
- Identification
- Flags (DF, MF)
- Fragment offset
- Time to live
- Protocol
- Header checksum
- Source address and destination address
- Options

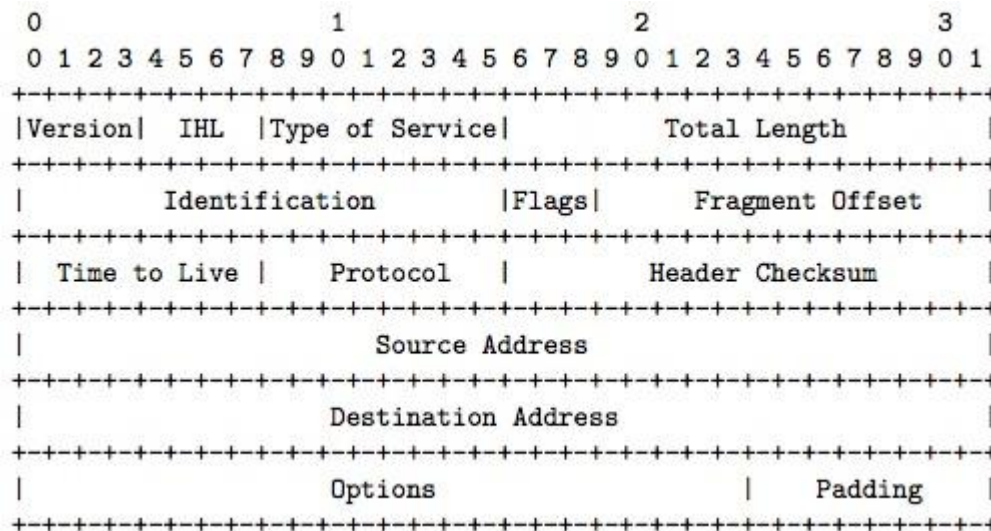

Layer 3: Network Layer Internet Protocol (IP v4)

- Total length
 - The total length relates to the whole datagram: header and data.
- Time to live
 - Determines the lifespan of an IP packet.
 - Maximum lifespan of an IP packet possible is 255 seconds.
- Source and destination address
 - These fields contain source and destination IP addresses, each of these addresses is 32-bit long.

Layer 3: Network Layer Internet-Protocol (IP)

- IP addressing
 - Every host and router on the internet has an IP address.
 - An IP address is unambiguous. Two computers cannot use the same (public) IP address at the same time.
 - The assignment of IP addresses is organised centrally by:
 - IANA (Internet Assigned Numbers Authority)
 - ICANN (Internet Cooperation for Assigned Numbers and Names)

Layer 3: Network Layer Internet Protocol (IP)

- The basis for the assignment of IP addresses is the RFC 2050.

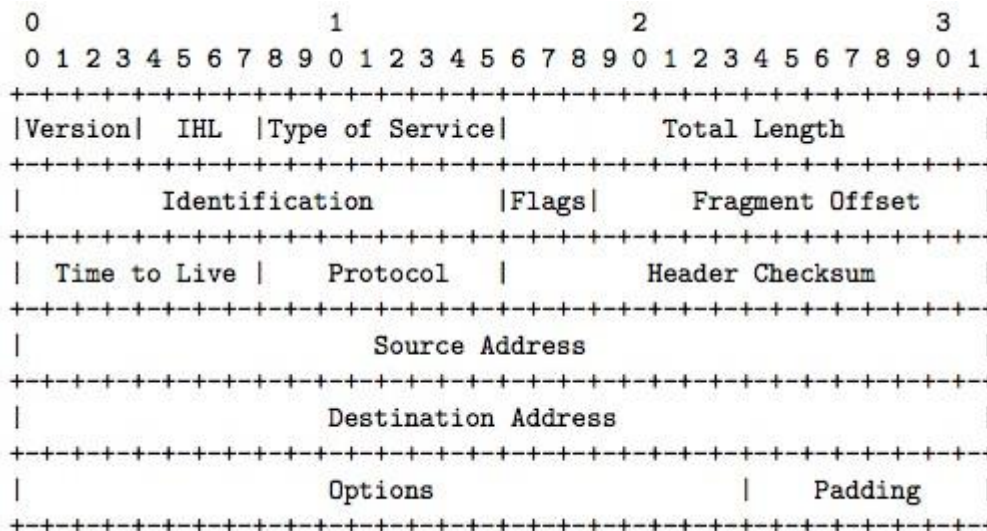

- All IPv4 addresses consist of 32 bits and they are used in the fields source and destination address.
 - Example: In binary, 140.212.54.123 becomes
 - 10001100-11010100-00110110-01111011

Layer 3: Network Layer Internet Protocol (IP)

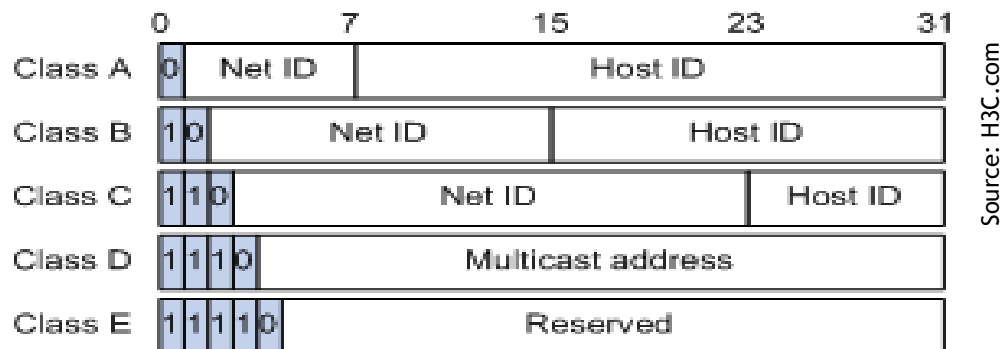

Five classes of IP address spaces are differentiated

- Class A
 - The first byte has a value of less than 127.
 - The first byte identifies the network, the last three bytes identify the host.
 - 126 Class A networks have up to $2^{24} - 2 = 16,277,214$ hosts each.
 - Address space: 0.0.0.0 to 126.255.255.255
 - 127.0.0.0 to 127.255.255.255 reserved for loopback
- Class B
 - The first byte has a value between 128 and 191.
 - The first two bytes identify the network, the last two identify the host.
 - Thus, 16,382 Class B networks exist and each of them has up to $2^{16} - 2 = 65,534$ hosts.
 - Address space: 128.0.0.0 to 191.255.255.255

Layer 3: Network Layer

Internet Protocol (IP)

- Class C
 - The first byte has a value between 192 and 223.
 - The first three bytes identify the network, the last byte identifies the host.
 - 2 million Class C networks have up to $2^8 - 2 = 254$ hosts each.
 - Address space: 192.0.0.0 to 223.255.255.255
- Class D - Multicast addresses
 - Address space: 224.0.0.0 to 239.255.255.255.
- Class E - Experimental addresses or for future use respectively
 - Address space: 240.0.0.0 to 247.255.255.255.

Layer 3: Network Layer Internet Protocol (IP)

- Examples:
 - Class A IP address: **10.5.5.1**
 - Class B IP address: **172.16.5.1**
 - Class C IP address: **192.168.5.1**
- IPv4 supports $2^{32} = 4,294,967,296$ addresses
- **But: There are no more unallocated IPv4 Internet addresses left!**

Source: ICANN (2011)

- Enhancements in IPv6
 - An IPv6 address is consists of 128 bits (instead of 32 bit).
 - IPv6 addresses are not written in decimals (like e.g. 80.130.234.185), but in **eight groups of four hexadecimal digits**, separated by colons (e.g. 485A:B722:0DEF:3188:CE45:651A:2134:E0F0).
 - The new IPv6 address space supports 2^{128} addresses = 340,282,366,920,938,463,463,374,607,431,768,211,456
 - IPv6 provides enough addresses in order to permanently assign a unique address to any existing internet device - worldwide. What does this mean in terms of user privacy?

- IPv6 Example:

2001:0db8:85a3:08d3:0000:0000:0000:7344

Within a **16-bit value**, leading zeroes may be omitted:

2001:db8:85a3:8d3:0:0:0:7344

A single occurrence of consecutive groups of zeroes within an address may be replaced by a double colon:

2001:db8:85a3:8d3::7344

- Introduction: Information & Communication
- OSI Model
 - OSI Model Overview
 - Layer 2: Data Link Layer
 - Layer 3: Network Layer
 - Layer 4: Transport Layer
 - Layer 7: Application Layer

Layer 4: Transport Layer Definition

- Transport layer (layer 4) constitutes an “interface” between the transport-oriented layers below and the application-oriented layers above.
- It takes care of the data transport from the source to the destination (logical end-to-end connection), independent from physical networks.
- The following services are provided to higher layers by the transport layer:
 - **Setup, coordination and termination of connections (3-way-handshake)**
 - Flow control and buffering
 - Multiplexing
- Important protocols:
 - Transmission Control Protocol (TCP)
 - User Data Protocol (UDP)

Layer 4: Transport Layer Transmission Control Protocol (TCP)

- The Transmission Control Protocol (TCP) was especially designed in order to provide a reliable and connection-oriented transportation of a byte-stream (from endpoint to endpoint) through unreliable networks.
- TCP is defined in RFC 793 (September 1981).

Layer 4: Transport Layer Transmission Control Protocol (TCP)

- Properties of TCP
 - Reliable
 - Data communication is repeated until the remote station acknowledges the receipt.
 - Connection-oriented
 - Before the actual data transfer begins, during setup of a TCP connection by 3-way handshake, a logical end-to-end connection between sender and receiver is established.
 - Makes it possible to send information directly to an application (ports).

Layer 4: Transport Layer 3-Way Handshake (TCP)

- Example from everyday life - making an appointment via correspondence

Prof. Rannenbergr wants to make an appointment with Prof. König via correspondence.

1. Prof. Rannenbergr sends a message to Prof. König to suggest an appointment date.
2. Prof. König confirms the appointment date by sending a message back to Prof. Rannenbergr.
3. Prof. Rannenbergr sends a message to Prof. König to let him know that he received the confirmation message.

Step 3 is necessary in order for Prof. König to know that Prof. Rannenbergr has received the confirmation. Message No. 2 could have gotten lost and then Prof. König would show up alone for the meeting.

Setup of a TCP connection by 3-way handshake

- Computer (client) sends a **SYN** to the remote station (server). **SYN** packets („synchronise“) have a sequence number x .
- Sequence numbers are important in order to determine if the transmission was completed in the correct order and without duplicates.
- The remote station (server) receives the **SYN** packet.
 - In case the port is closed, it replies with **TCP-RST**.
 - In case the port is open, it sends a **SYN ACK** providing its own starting sequence number y . At the same time, the remote station acknowledges the receipt of the first **SYN** packet by increasing its sequence number by one and including it in the **ACK** part (“acknowledgment”) of the header.
- The computer (client) receives and acknowledges receipt of the **SYN ACK** packet by sending an **ACK** packet with the sequence number $y+1$ (this is also called a „forward acknowledgement“). Also, the client sends the sequence number $x+1$ to the server.
- This **ACK** segment contains information about the remote station and the **ACK** flag serves as a label.
- Connection has been successfully set up and the actual data transmission can start.

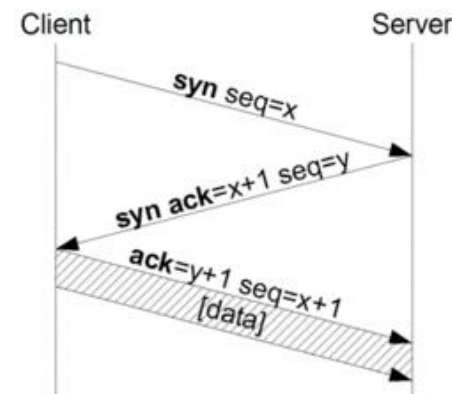

Layer 4: Transport Layer User Data Protocol (UDP)

- User Data Protocol (UDP) is a connectionless, insecure transport protocol without assurance whether a data packet has been received by the remote party or not.
- UDP has the advantage of a reduced protocol overhead compared to the Transmission Control Protocol (TCP).
- UDP is used e.g. for the Domain Name System (DNS, sometimes also known as Domain Name Service).

- Introduction: Information & Communication
- OSI Model
 - OSI Model Overview
 - Layer 2: Data Link Layer
 - Layer 3: Network Layer
 - Layer 4: Transport Layer
 - Layer 7: Application Layer

Layer 7: Application Layer Definition

- All layers below the application layer serve the purpose of ensuring reliable transport of data, but they do not perform any specific tasks for the user.
- The application layer contains a multitude of protocols which are often needed by users in order for applications to work.
 - DNS
 - E-Mail
 - FTP
 - HTTP
 - Skype
 - ...

Layer 7: Application Layer

Example: Domain Name System

- Introduction of a distributed database, the „Domain Name System“ (DNS).
- The DNS is located on the application layer.
- The DNS translates names into addresses, addresses into names or provides e.g. information about the IP address of a mail server for a domain (mail exchange or MX record).
- There are three types of DNS Servers:
 - Local: DNS server inside the organisation (of your own)
 - Root: Root DNS of a domain
 - Authoritative: Authoritative name servers are assigned to be responsible for particular domain names.

Layer 7: Application Layer

Example: Domain Name System

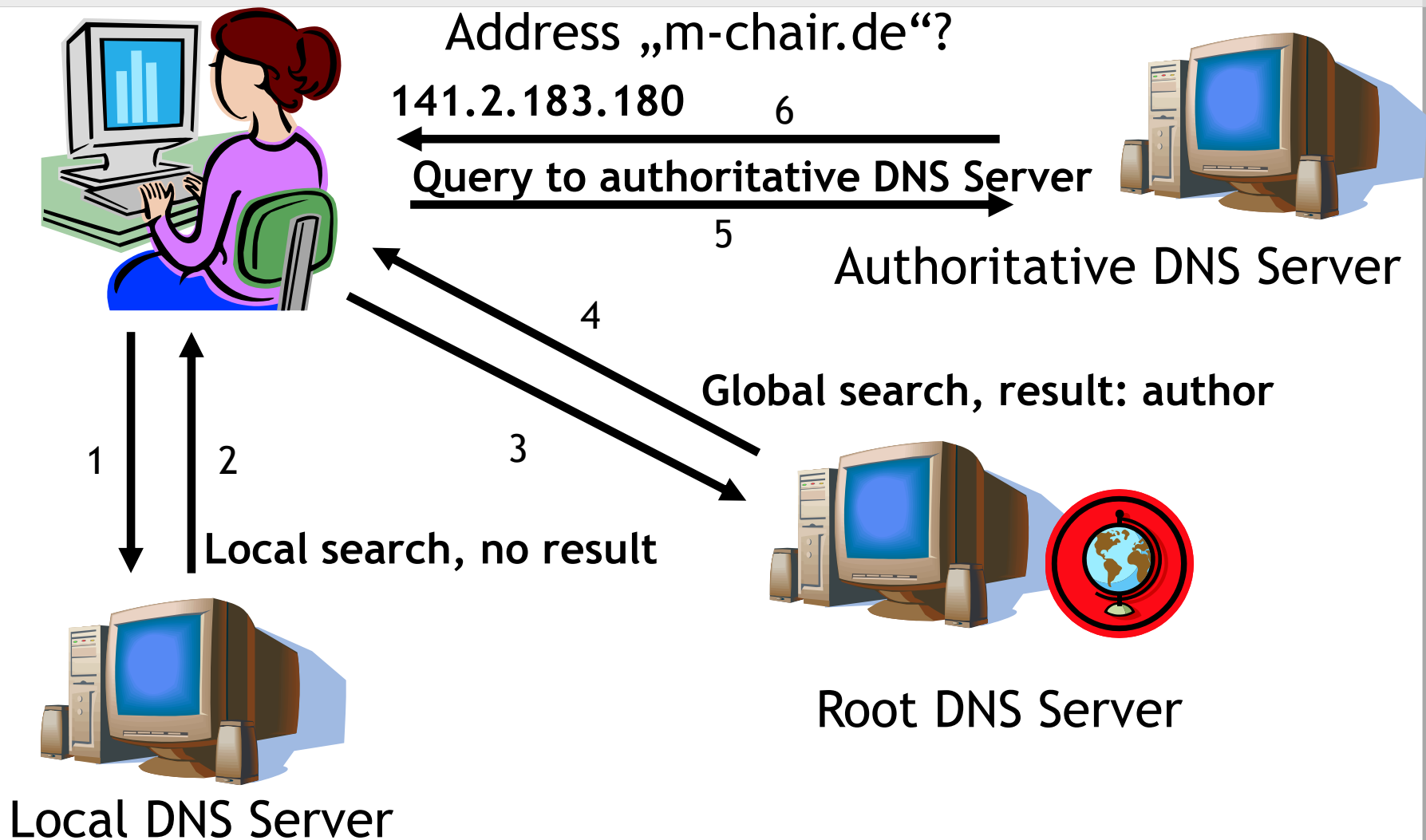

Layer 7: Application Layer

Example: DNS Forwarding

Aim: Load-balancing for DNS queries

Address „m-chair.de“?

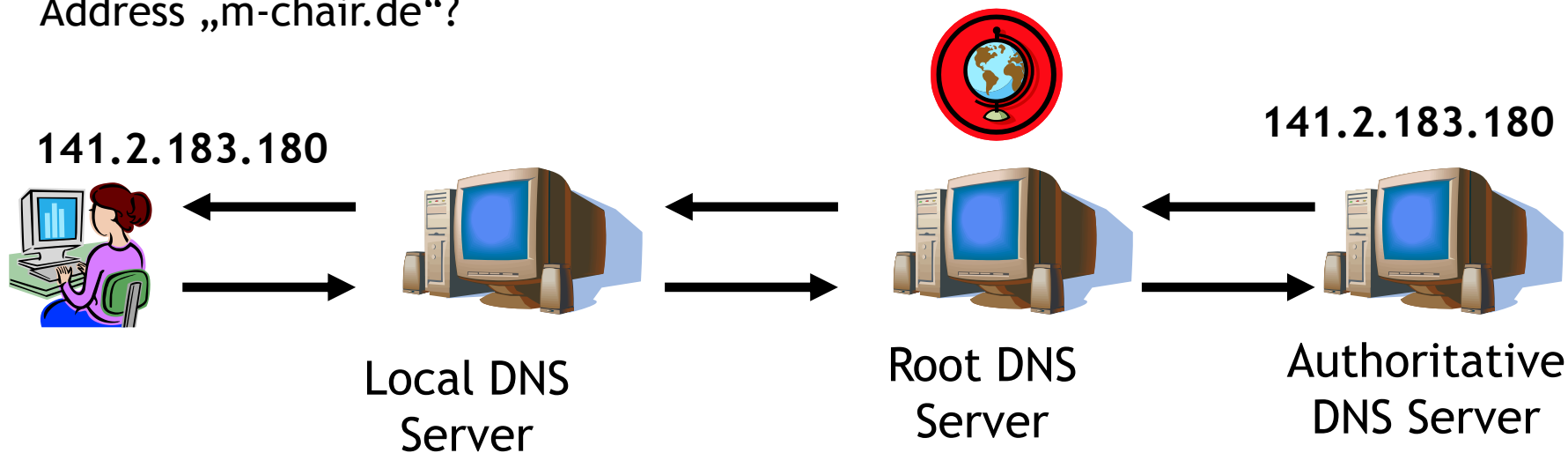

Layer 7: Application Layer

Example: DNS and Layers

DNS queries involve all the layers of the network stack.

Adresse „m-chair.de“?

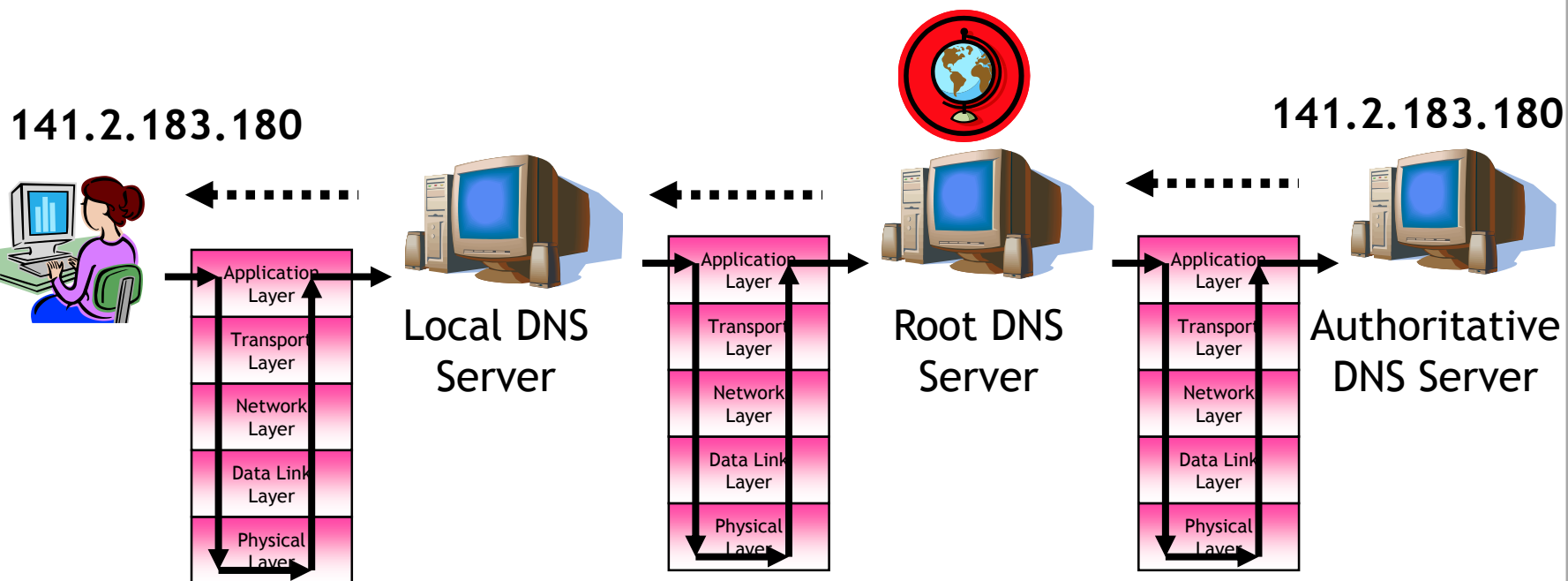

The

- Layer 1: Physical Layer,
- Layer 5: Session Layer, and
- Layer 6: Presentation Layer

are also important, but are not in the focus of this lecture.



- DATACOM Buchverlag GmbH (2005) “IP-Protokoll“, <http://www.itwissen.info/>, last accessed 2013-07-03.
- Eicker, S. (2006) “Grundlagen betrieblicher Kommunikationssysteme“, Skript Uni-Duisburg-Essen.
- Holtkamp, H. (2002) “Einführung in TCP/IP“, <http://www.rvs.uni-bielefeld.de/~heiko/tcpip/>, last accessed 2013-07-03.
- Internet Corporation For Assigned Names and Numbers (ICANN) (2011) “Available Pool of Unallocated IPv4 Internet Addresses Now Completely Emptied“, icann.org/en/news/releases/release-03feb11-en.pdf , last accessed 2013-07-03.
- Tanenbaum, A.S. (2006) “Computernetzwerke“, ISBN-10: 3827370469.
- https://en.wikipedia.org/wiki/Communication_protocol