

Practical Exercise 3

Technology II

Mobile Business I (WS 2014/15)

Prof. Dr. Kai Rannenber

Deutsche Telekom Chair of Mobile Business & Multilateral Security
Johann Wolfgang Goethe University Frankfurt a. M.



- This set of slides is based upon the following lectures:
 - **Lecture 8:** Smartcards and Related Application Infrastructures
 - **Lecture 9:** Mobile Devices
 - **Lecture 10:** Concepts of Mobile Operating Systems
 - **Lecture 11:** Market Overview of Mobile Operating Systems and Security Aspects

- a) What are smartcards and what components do they consist of (=what do they contain)?

- Small computers with **memory, operating system, software, processor, I/O and access control**
- **Chip protected against manipulation**
- After being **initialised with keys** and other data smartcards are distributed to their users.

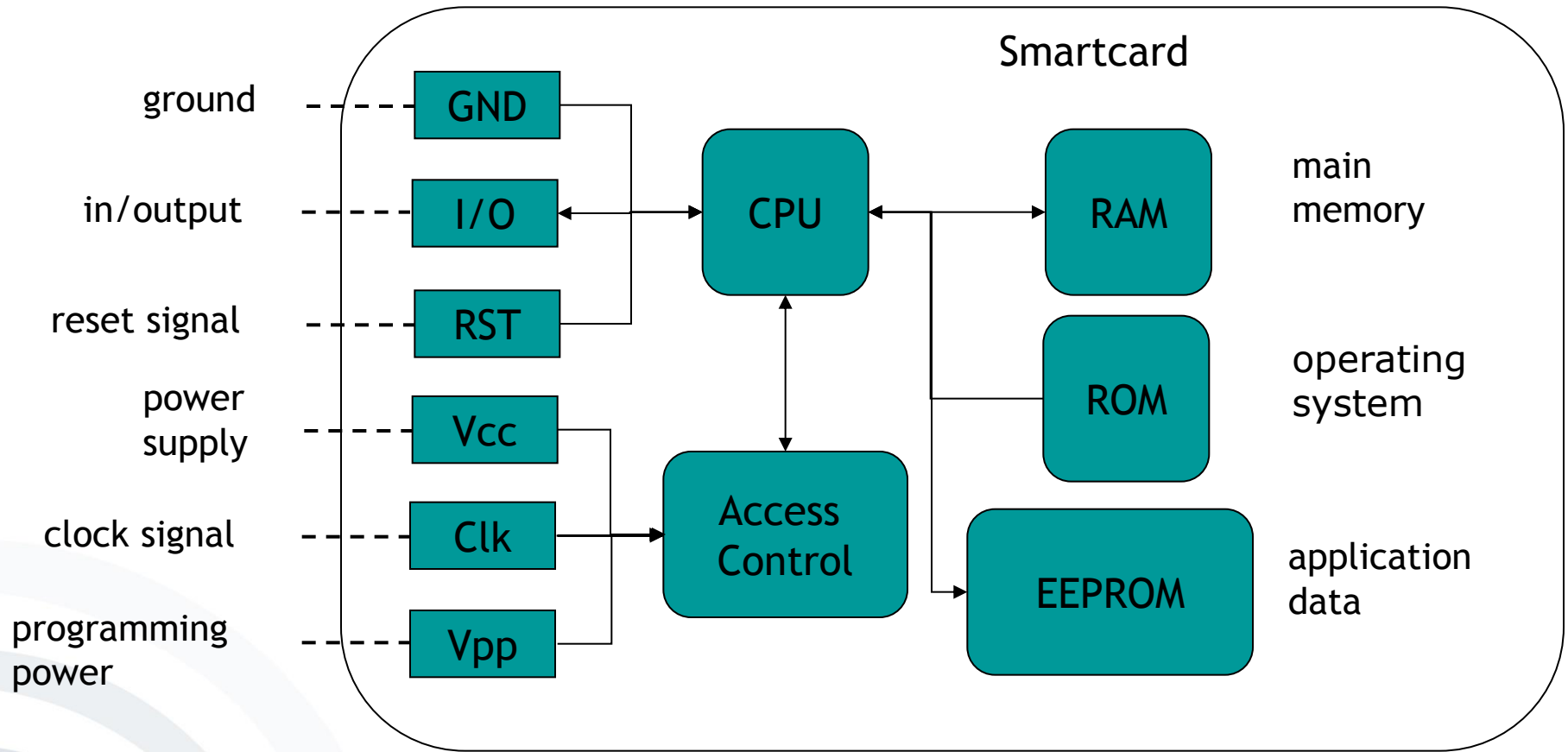

1a

Source: SecCommerce2002]

- b) Why are they used and what role do smartcards play with respect to
 - (i) security
 - (ii) applications?

- Used when **security** of data (e.g. for keys, signatures, physical access control, payment) is needed in **insecure environments**
- **Examples:**
 - Phone cards of Deutsche Telekom
 - Signature cards according to German Signature Law
 - Smartcard applications for PC
 - Smartcards for mobile communication (SIMs)



1b

Protection needed against:

- Unauthorised usage of services through forged user data
- Duplication of a user's credentials
- „Cracking“ of credentials
- Billing fraud

CELLULAR COUNTERFEITING/CLONING FRAUD

Cellular Phone Counterfeiting

With each call made, a cellular phone transmits an Electronic Serial Number (ESN) and a Mobile Identification Number (MIN) identifying the caller. Possession of these numbers is the key to the counterfeiting.

Example for faulty system design (CDMA)

Duplication of intercepted user IDs

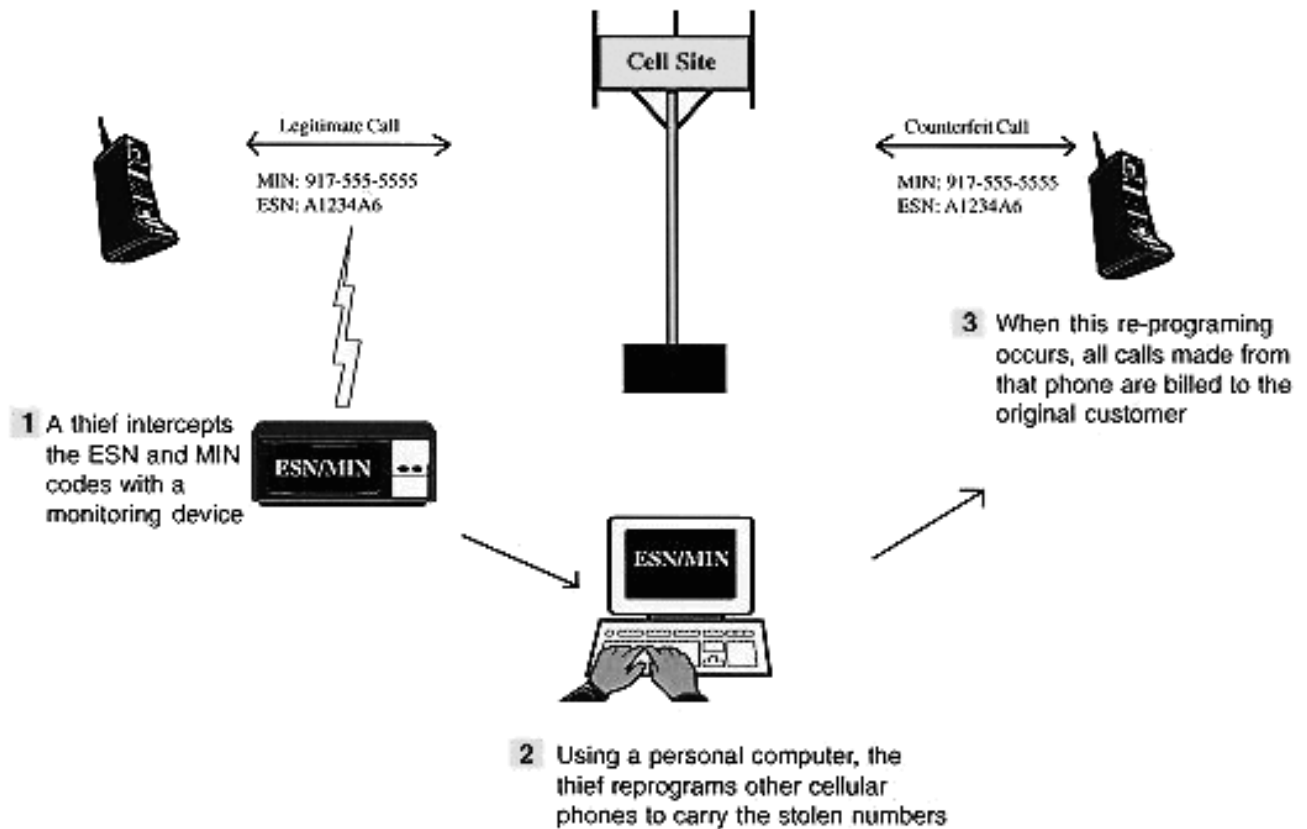

1b

- a) Name the most important function of the Subscriber Identity Module (SIM) in GSM and UMTS networks.

The Subscriber Identity Module (SIM)

- In GSM and UMTS since 1991, upcoming for WLAN
- **Represents contract between subscriber & network operator**
- Authorises a “phone” to use the network by linking it to a **subscription**
- By November 2014 more than **7.2 billion** mobile-cellular subscriptions
[ITU2014, GSMAI2014]
- **More** countries with **SIM** infrastructure (219, 2013-Q3) **than** with **McDonald’s** (118, 2013-Q3) and **more than UN** member states (193, 2013-Q3) [GSM2013, McDonalds2013, UN2013]
- More and more called “Subscriber Identification Module” to reflect progress in the general field of **Identity Management**



- b) What does the Subscriber Identity Module contain? Which of these contents are protected, which are not and why?

- Protected data:
 - IMSI, PIN, PUK
 - A3, A8 crypto algorithms
 - List of subscribed services
 - Language used by the subscriber
- Dynamic data:
 - Cell information
 - Frequency information
 - Dynamically generated (session) keys
 - Attributes of GSM login
 - User data (address book, telephone list, SMS memory)

- c) Name other functionalities of the Subscriber Identity Module.

- SIM serves as „**identity card**“ for GSM cellular phone subscribers.
- SIM identifies the **issuer of the card** – important for the **billing of roaming subscribers** by roaming partner.
- SIM allows for **secure billing of roaming subscribers** through SIM-cryptography – important for card issuer.
- SIM contains additional **configuration data** of the GSM system.

- **SIMs are Smartcards:**
 - SIM cards serve as security medium.
 - Tamper-resistance prevents counterfeiting.
 - robust design
- Contain **International Mobile Subscriber Identity (IMSI)** for subscriber identification and the key K_i provided by the mobile operator
- Reliably execute computational functions for the mobile device

- d) What is SIM Application Toolkit?
 - (i) What does it do?
 - (ii) Name application examples for SIM Application Toolkit.

- **ETSI GSM 11.11** [GSM2006] specifies electrical as well as software interfaces between SIM and device.
- A **serial interface** is used for accessing the card.
- Communication through **SIM commands**
- Device can access **files** or execute **actions** through SIM commands.
- „SIM Application Toolkit“ allows for implementing of **additional applications** on a SIM.

- Provides an interface for **Value Added Services** implemented on **programmable SIMs** for interacting with mobile devices
- **Standardised 1996** as ETSI GSM 11.14, extended 1999 [GSM2006]
- **Controls I/O, Telephony, Download**
- Allows for **security functionality**
- „Living standard“

- **Mobile Banking and Brokerage**
 - T-Mobile and T-Online SMS banking
- **Secure payment** via cellular phone
- **Authentication** of users trying to access servers
- **Location-based services**
 - ATM search, navigation
- **Security applications in general**
 - Mobile signatures

a) What is a USIM?

- **Standardised** in 3GPP TS 21.111 and 3GPP TS 31.102 [GSM2006]
- **Successor** of SIM in 3G networks (but 3G networks are downward compatible to many SIMs)
- Supports different „virtual“ **USIMs** and **SIMs** on one cards – i.e. multifunctional smartcard
- Specified as „**UMTS-SIM**“, to support authentication, authorisation and computation of future services

b) Name the innovations introduced with the USIM.

Visions of new Opportunities

- **Market entry of USIM „disguised“ as SIM**
 - ➔ UMTS activated by operator
- **Multiple USIMs – possibly from competing providers – can technically coexist on one card. Selection via menu on mobile device**
 - ➔ Reduction of operator switching cost
- **Switching to anonymous prepaid USIM as a privacy option when using privacy sensitive services?**

c) What is a UICC and how do USIMs relate to a UICC?

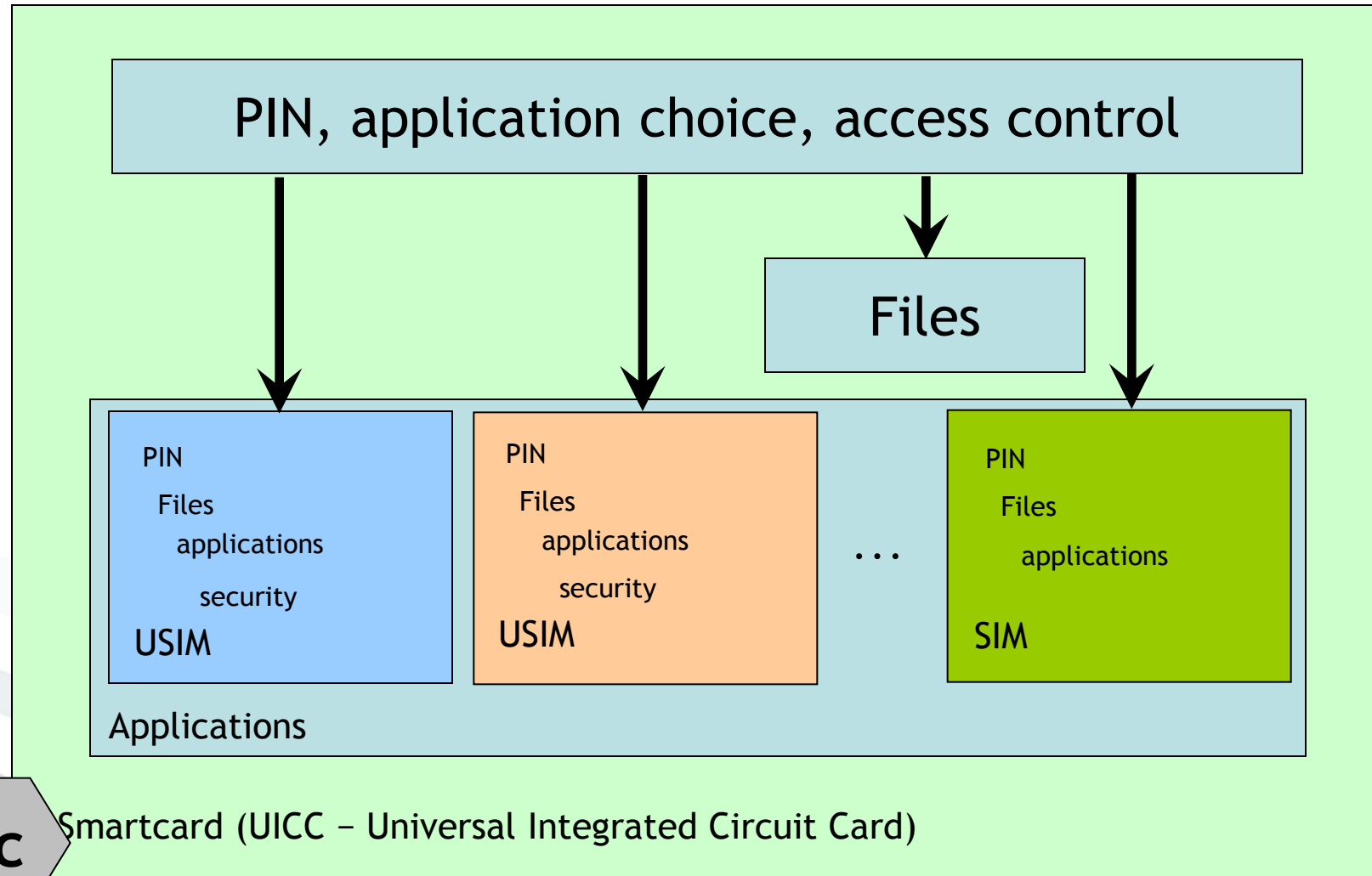

3c

Smartcard (UICC – Universal Integrated Circuit Card)

d) Describe market opportunities and effects of competing USIMs.

- **Support for multiple applications**
- **End-to-end security** from the USIM to the application
- **Authentication of the network towards the USIM via cryptography**
 - ➔ **Multilateral Security is possible!**
- **Downward compatible to SIM**
- **Extended phone book on card:**
 - Email addresses
 - Multiple names & numbers for each entry
 - More memory
 - Standardised entries

- a) How can mobile devices be categorized?
 - (i) Technical characteristics
 - (ii) Application Aspects

- Categorisation is possible by:
 - Technical characteristics
 - Application aspects
 - Functional completeness (Is the functionality comparable to a desktop PC/Laptop?)
 - Size of the terminal/device
 - Security features

- Hardware independence
 - Independent terminals
 - Terminals with external communication
 - Terminals with external security modules
 - Terminals with external memory
- Operating system – Characteristics
 - Memory security, file security, access control
 - Security module support, secure I/O, program and system integrity

- Lifespan of an application
 - Battery consumption, amount of data, and size of memory
 - Data integrity, amount of communication, and costs
- Completeness of the functionality for the end-user
 - Information / Reaction
 - Limitations due to device size
 - Feature Sets

- Device size
 - Small / integrated devices
 - „Pocket-sized“
 - „Laptop-sized“
- Access to the security module
 - Data integrity, encryption
 - Digital signatures
 - Access control, authentication

- Different requirements for different kinds of devices:

	Mobile Phone	Tablet	Laptop
<i>Number of „Switch-ons“ per day</i>	low	low	variable
<i>Frequency of use cases</i>	very high	rather low	low
<i>Duration of usage per task</i>	?	short/ medium	high

4a

Based on [Burckhardt2001]

- b) Name four components of mobile devices.
Which two of these components do considerably determine the size of a mobile terminal?

- The size of a mobile terminal is considerably determined by its:
 - Input Facilities (e.g. keyboard)
 - Output Facilities (e.g. display)
- ➔ Separation of components (e.g. display in the watch, head-mounted-displays)

c) Describe the functional architecture of a mobile device.

OS - Functional Architecture

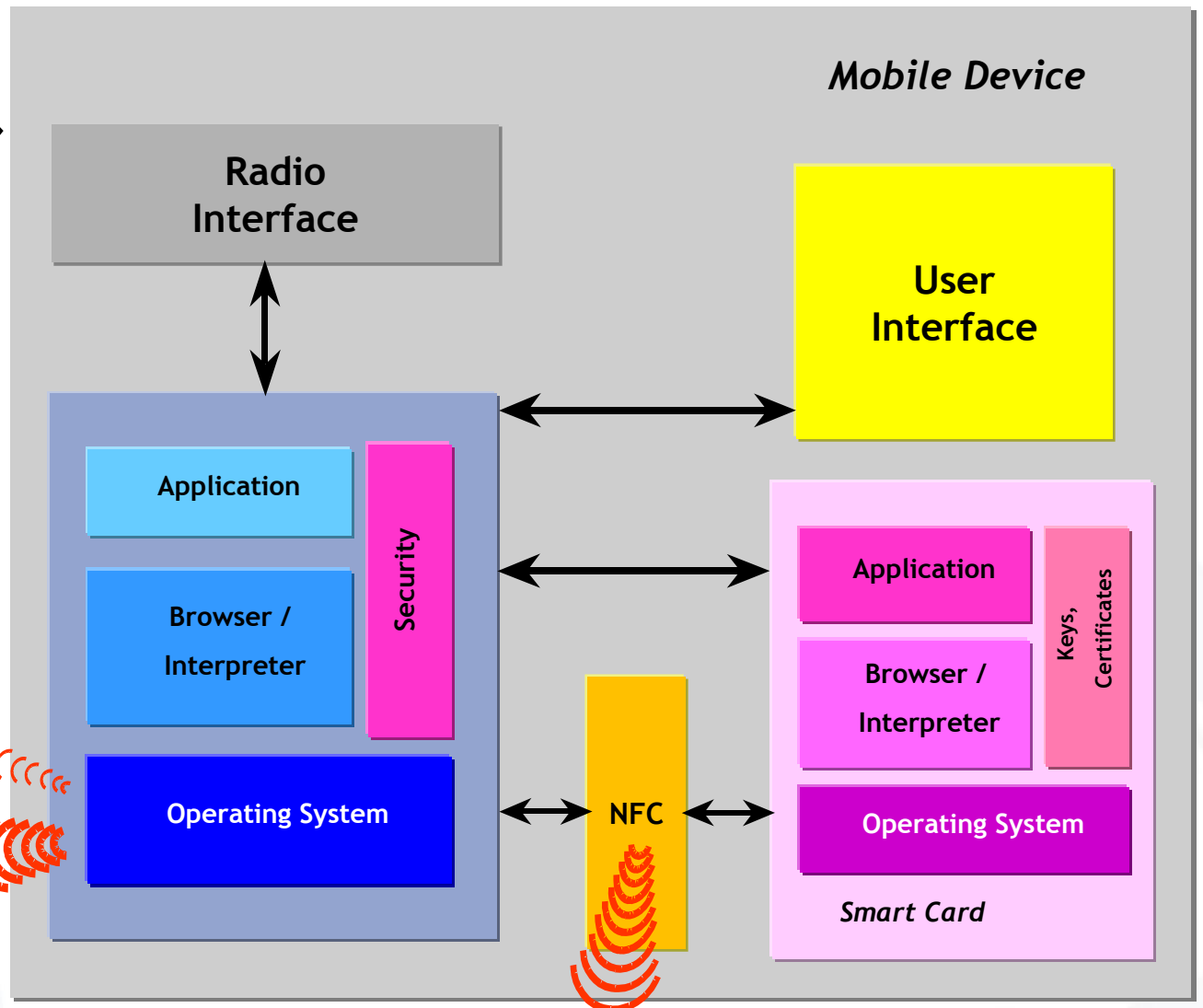
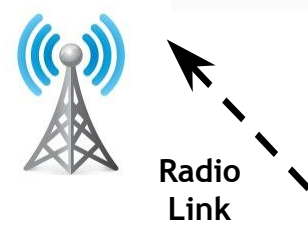

Global Positioning System (GPS)



PAN: Bluetooth, Infrared, ...

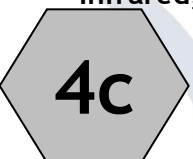
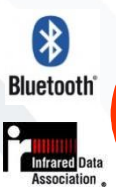

Based on [Posegga2001]

Near Field Communication (NFC)

- a) Personal Area Networks (PAN) - what are they good for, what do they do?

Personal Area Network (PAN)

- Personal environment, short range
- **Purpose:** Connection of devices in short range, for example mobile device and printer.
- Replaces cable-connections:
 - Infrared Data Association (IrDA)
 - Bluetooth
 - Near Field Communication (NFC)

- b) Please do briefly describe the related technologies IRDA and Bluetooth. Name the advantages and disadvantages of both IRDA and Bluetooth.

- IrDA: Infrared Data Association (1993):
- Standardized infrared-protocols
- Asynchronous, serial connections up to 115 kbit/s (Serial Infrared) or 4 Mbit/s (Fast Infrared)
- Point-to-Point
- Protocol-family for various purposes



- Exemplary applications:
 - Transmission of mobile business cards
 - Sales data extraction from cigarette vending machines
 - Connection between mobile and laptop
 - Wireless printing
 - Remote control for consumer electronics, e.g. TVs

- Attributes:
 - Wireless
 - Range of up to 10 meters
 - Illumination-angle 15° - 30°
- Disadvantages:
 - **Sounding:** If the infrared-ray misses the target
 - Optical connection required
 - Short interruptions of the optical connection, e.g. between laptop and mobile phone in trains, lead to complete network-interruption.

- Frequency range of 2.4 GHz
- Simple and cheap possibility to set up ad-hoc networks of limited range (up to 10 meters)
- No official standard, but de-facto-standard
- Consortium: Ericsson, Intel, IBM, Nokia, Toshiba, etc.
- Broadly supported by related industries:
 - Computer hardware
 - Software
 - Consumer electronics
 - ...

Personal Area Network (PAN)

Popular Bluetooth Applications

Wireless communications between devices
(Bluetooth-Headset)

Sound transmission
(to earphones, headphones
or Hi-Fi equipment)

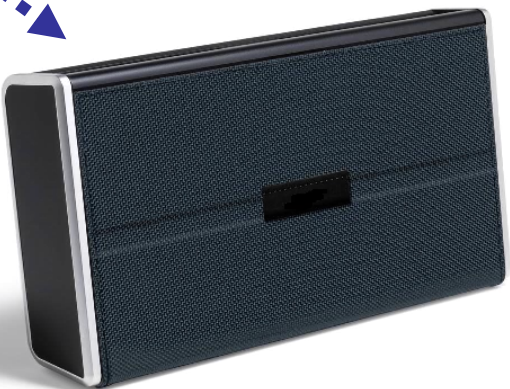
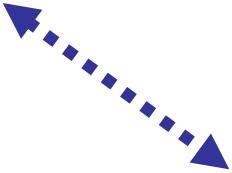

5b

- Connection of periphery-devices (headsets, keyboards, mice, etc.)
- Setting up of ad-hoc networks for spontaneous data exchange
- Ad-hoc connection of different networks (e.g. laptop ↔ mobile or phone ↔ GSM ↔ net)
- Applications similar to applications based on infrared technology
- Weaknesses of infrared technology were overcome
 - Increased bandwidth (up to 865.2KBit/s)
 - No optical connection between devices necessary
 - Expanded range (up to 10m)
 - Allows setting up of ad-hoc networks instead of point-to-point connections





- a) What are the advantages and disadvantages of mobile operating systems unavailable to other device manufacturers?

Mobile OS unavailable to other device manufacturers

- Originally, most mobile phone manufacturers used their own “closed” operating systems for their mobile devices.
- Later, more and more platforms switched to more open and interoperable operating systems (e.g. Windows CE, Symbian OS, Android).
- Some manufacturers (still) rely on own OS, e.g. RIM Blackberry OS, Apple iOS.
- **Advantage:** Tend to be not as much affected by malware than “open” operating systems
- **Disadvantage:** Less flexible, as 3rd-party software cannot be easily installed and executed

- b) Name two mobile operating systems unavailable to other device manufacturers and two manufacturer-independent mobile operating systems.

- **Palm OS (Garnet OS)**
 - Latest release: Most devices equipped with Palm OS 5.4
- **Apple iOS (Unix-based)**
 - Latest release: iOS 8
- **BlackBerry OS**
 - Latest release: BlackBerry OS 10.3
- **Nokia Series 40, Asha**
 - Latest release: Asha 1.4
- **Samsung bada**
 - Latest release: 2.0

- Linux: LiMo (Linux Mobile), Openmoko Linux, Qt Extended (Qtopia) 
- Symbian platform
 - Latest release: “Nokia Belle Feature Pack 2” for Symbian^3 devices
- Android (by Open Handset Alliance) 
 - Latest release: 5.0 (Lollipop)
- Windows Mobile
 - Latest release: Windows Mobile 6.5.5
- Windows Phone
 - Latest release: Windows Phone 8.1
- Maemo (by Nokia) → MeeGo (by Nokia, Intel) → Sailfish OS (by Jolla) 
 - Latest release: Sailfish OS v1.1.0.39 (October 2014)
- Tizen (by Samsung, Intel, Linux Foundation) 
 - Latest release: 2.3 (November 2014)
- Firefox OS (by non-profit organisation Mozilla) 
 - Latest release: 1.4 (August 2014)
- China-Focused Mobile OS
 - Currently under development by Taiwan-based HTC [WSJ2013]

- c) When mobile operating systems allow the execution of 3rd-party software, what are the threats resulting from this for the user?

- Many mobile operating systems allow the execution of 3rd-party software:
 - Malware can be executed on mobile operating systems, either intentionally or by security leaks inside the mobile operating system (exploits).
- Possible threats for the user are:
 - Device malfunction
 - Loss of data (malware erasing data)
 - Loss of money (e.g. malware sending SMS to premium services)
 - Shorter battery runtime (more processing/resource usage)

Beginnings of Mobile Malware

- **09/2000:** Liberty Horse Trojan
- **12/2000:** Telefonica SMS Mailer
- **08/2001:** Flooder sends unwanted SMS
- **09/2001:** Phage erases data on Palm devices
- **02/2003:** Nokia V-Card exploit
- **09/2004:** First Symbian OS malware
- ...

Strong growth of Mobile Malware

- The number of malware programs masquerading as legitimate mobile apps grew by more than 600 percent in 2012

6c

Most popular target: Android



[ATD2013]

10 years of malware for mobile devices

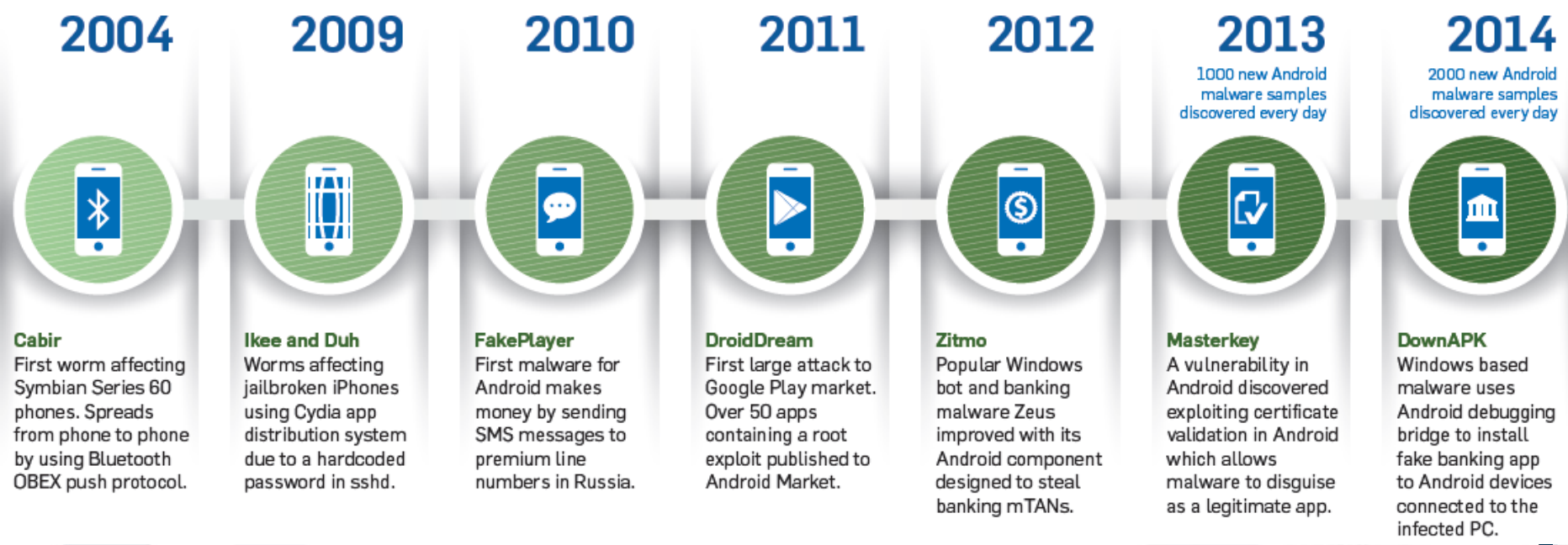

1000 new Android malware samples discovered every day

2000 new Android malware samples discovered every day

d) What are the security precautions and countermeasures available in mobile operating systems?

- Memory protection
 - Processes are not able to access the memory of other processes.
- File protection
 - Encryption
 - Access control
- Access controls
 - Definition of access rights and monitoring of their enforcement.
- Support for security modules
- Secure I/O
- Code integrity management: Integrity of programs is checked before they are started by e.g.
 - Checking certificates
 - Proof Carrying Code
- Additional Security Software may be needed, e.g.
 - Virus scanners
 - Firewalls

- a) What is the primary goal and what is the secondary goal of an OS?



What is an operating system (OS)?

- An OS is a program that serves as a mediator between the user and the hardware.
- It enables the users to execute programs
- *Other properties:* Multi-user, multi-thread, high availability, real-time, ...

- *Primary goal of an OS:* Easy usage of the actual hardware
- *Secondary goal of an OS:* Efficient usage of the hardware

7a

- b) Name three functions of the operating system and state two examples (exemplifications) for each of these functions.



- **Controlling and sharing of resources**
 - Computation time, real-time processing
“Who is computing how much? How long does it take?”
 - Memory (RAM, Disk)
“Who gets which part of the memory?”



- **Security functions**
 - Protection of the data (memory, hard disk):
“Who is allowed to access resources?”
 - Process protection (computation time, code, isolation):
“Who is allowed to compute?”
 - Security module support



- **Communication**
 - Allocation of I/O-Resources
 - Processing of the communication
 - User interface (UI)

c) What is a process? What does it do, what does it use and how is the mobile operating system involved?

- A process is a program “in operation”.
- A process uses resources, such as CPU time, memory, files, and I/O devices.
- The resources of a process are allocated while it is created or when it is running.
- The operating system has to manage the process (creation, resource distribution, etc.).

- More than simple code!
- Program counter: Indicates on which point in the code the process resides.
- Contents of the process registers:
 - **Stack**: Contains temporary data, such as subroutine parameters or return addresses, etc.
 - **Data section**: Contains the global variables
 - **Heap**: Dynamically allocated memory

d) Which are the states of a process?

States of a Process

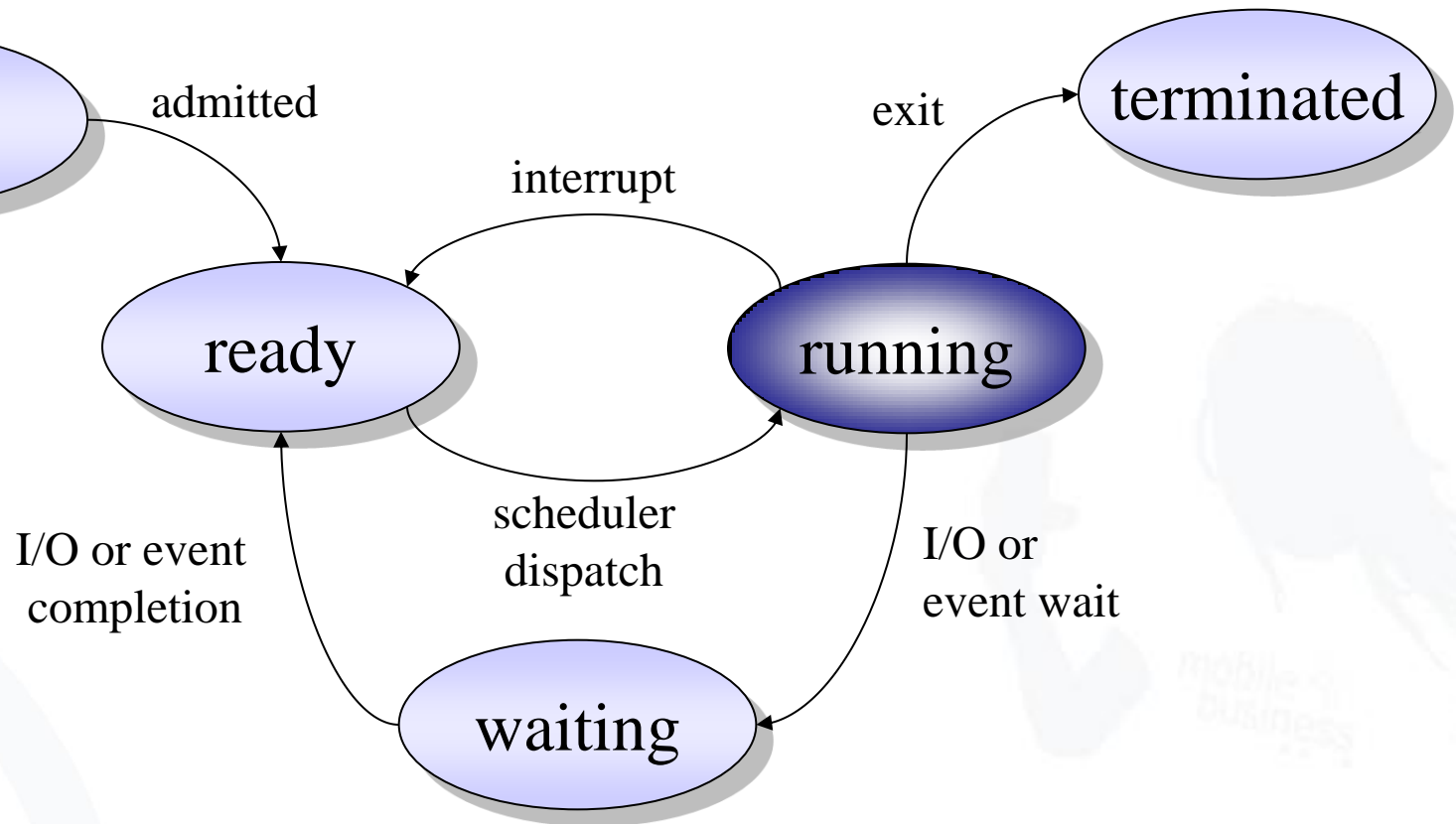

- **New:** Process is created.
- **Ready:** Process is waiting for being executed.
- **Running:** Process is running.
- **Waiting:** Process is waiting for results:
 - Completion of an I/O-operation
 - An event
- **Terminated:** Process is terminated.

Abstracted View on a Process: Process Control Block (PCB)

- Abstracted representation of the contents of a process control block (PCB), needed by an operating system.

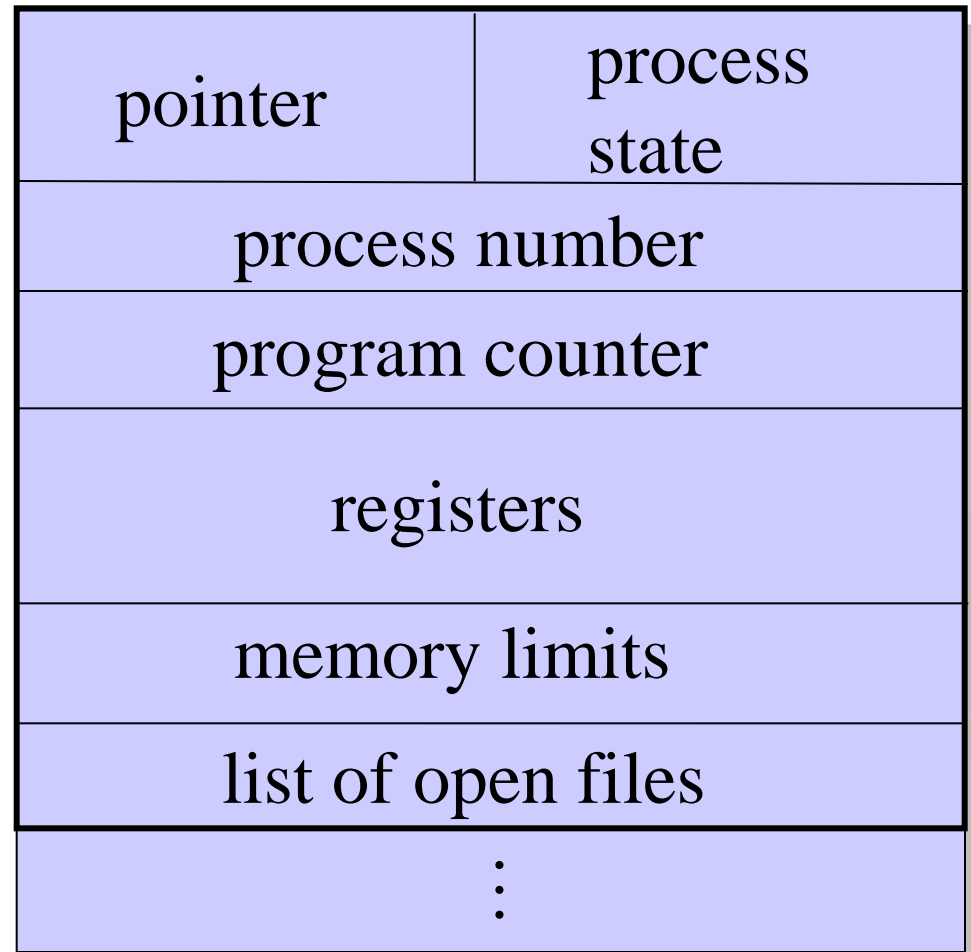

- **Process State:** *new, ready, running, waiting, ...*
- **Program Counter:** Address of the next command to be executed
- **CPU Registers:** Accumulator, Index Register, Stack Pointer and general registers
- **Information for:**
 - CPU-Scheduling
 - Memory-Management
 - Accounting
 - I/O Status

- This set of slides is based upon the following lectures:
 - **Lecture 8:** Smartcards and Related Application Infrastructures
 - **Lecture 9:** Mobile Devices
 - **Lecture 10:** Concepts of Mobile Operating Systems
 - **Lecture 11:** Market Overview of Mobile Operating Systems and Security Aspects